



OPERATORS MANUAL

FOR

MODEL 6634A

Temperature Stabilized
RESISTANCE STANDARD

NOTICE

The contents and information contained in this manual are proprietary to Guildline Instruments Limited. They are to be used only as a guide to the operation and maintenance of the equipment with which this manual was issued and may not be duplicated or transmitted by any means, either in whole or in part, without the written permission of Guildline Instruments Limited.

OM6634A-B5-00
23 June, 2026

TABLE OF CONTENTS

1. INTRODUCTION.....	1-1
1.1. SCOPE.....	1-1
1.2. GENERAL DESCRIPTION.....	1-1
1.2.1. Resistance Ranges	1-1
1.2.2. Standard Model Configurations.....	1-1
1.3. FRONT PANEL INDICATORS AND CONTROLS	1-2
1.3.1. Power	1-2
1.3.2. Heater.....	1-2
1.3.3. Over Temperature	1-2
1.3.4. PRT.....	1-2
1.4. REAR PANEL CONNECTORS AND CONTROLS	1-3
1.4.1. Line Input Connector	1-3
1.4.2. Resistor Terminals	1-3
1.4.3. Guard Terminal.....	1-3
1.4.4. Chassis Ground Terminal	1-4
2. SPECIFICATIONS.....	2-1
2.1. GENERAL SPECIFICATIONS.....	2-1
2.2. RESISTANCE SPECIFICATION	2-2
3. OPERATING INSTRUCTIONS	3-1
3.1. INSTALLATION	3-1
3.2. OPERATING NOTES	3-1
3.2.1. Connection to Standard Resistors	3-1
3.2.2. Monitoring of the Internal Temperature	3-1
4. MAINTENANCE.....	4-1
4.1. PREVENTIVE MAINTENANCE	4-1
4.1.1. Cleaning.....	4-1
4.1.2. Temperature.....	4-1
4.1.3. Resistor Stability.....	4-1
4.2. CERTIFICATION OF RESISTANCES	4-1
4.3. CORRECTIVE MAINTENANCE.....	4-1
4.3.1. Preliminary Checks.....	4-1
4.3.2. Temperature Control.....	4-2
4.3.3. Over Temperature	4-4

5.	PRINCIPLES OF OPERATION	5-1
5.1.	INTRODUCTION	5-1
5.2.	TEMPERATURE SENSITIVE OSCILLATOR	5-2
5.3.	AMPLIFIER AND DETECTOR	5-2
5.4.	HEATER DRIVER	5-3
5.5.	OVERTEMPERATURE CIRCUIT	5-3
5.6.	POWER SUPPLY	5-4

TABLE OF FIGURES

FIGURE 1-1: FRONT VIEW	1-2
FIGURE 1-2: REAR VIEW	1-3
FIGURE 5-1: HEATER CONTROL UNIT	5-1
FIGURE 5-2: TEMPERATURE SENSITIVE OSCILLATOR.....	5-2
FIGURE 5-3: AMPLIFIER AND DETECTOR	5-2
FIGURE 5-4: HEATER DRIVER	5-3
FIGURE 5-5: POWER SUPPLY	5-4

LIST OF TABLES

TABLE 2-1: GENERAL SPECIFICATIONS.....	2-1
TABLE 2-2: RESISTANCE SPECIFICATION	2-2
TABLE 4-1: CONTROL CIRCUIT BOARD TESTING.....	4-2
TABLE 4-2: TRANSISTOR VOLTAGES	4-4

1. INTRODUCTION

1.1. SCOPE

This manual contains technical specifications, a detailed description, maintenance information, and diagrams for the Guildline Instruments model 6634A Temperature Stabilized Resistance Standard.

1.2. GENERAL DESCRIPTION

The model 6634A Resistance Standard is a rack mountable or bench top instrument which provides a set of precision resistance standards enclosed in a multi-walled constant temperature chamber. The internal temperature is maintained by a solid-state control system at $30\text{ }^{\circ}\text{C} \pm 0.01\text{ }^{\circ}\text{C}$. The design assures minimum thermal gradients within the inner chamber containing the standard resistors. The resistors are electrically isolated and attached to the chassis to resist shock and vibration.

To protect the standard resistors from overheating due to a malfunction of the temperature control, there is an overriding over-temperature control that will disable the heating system if the temperature exceeds $34\text{ }^{\circ}\text{C} \pm 3\text{ }^{\circ}\text{C}$.

The model 6634A is intended to be used as a Working Standard Resistance Reference for an automated resistance measurement system.

1.2.1. Resistance Ranges

The ten resistor elements within the model 6634A-10 cover the range of $0.1\ \Omega$ to $100\ \text{M}\Omega$ in decade steps. Each resistor element is isolated and has a 4-terminal connection at the back panel. The normal power to be applied to each resistor element is 10 mW. Other models are as described in section 1.2.2.

1.2.2. Standard Model Configurations

The following standard models are available with the resistance element ranges specified. Other variations can be supplied as a requested special build with any values of resistance from $0.1\ \Omega$ to $100\ \text{M}\Omega$.

Model 6634A-10 comprises a full complement of 10 elements from $0.1\ \Omega$ to $100\ \text{M}\Omega$ ohms in decade values.

Model 6634A-9 comprises 9 elements from $0.1\ \Omega$ to $10\ \text{M}\Omega$ in decade values.

Model 6634A-8 comprises 8 elements from $1\ \Omega$ to $10\ \text{M}\Omega$ in decade values.

Model 6634A-5 comprises 5 elements from $1\ \Omega$ to $10\ \text{k}\Omega$ ohms in decade values.

Note that 0.001 Ω and/or 0.01 Ω values can be ordered but they physically take more space so are delivered with fewer elements.

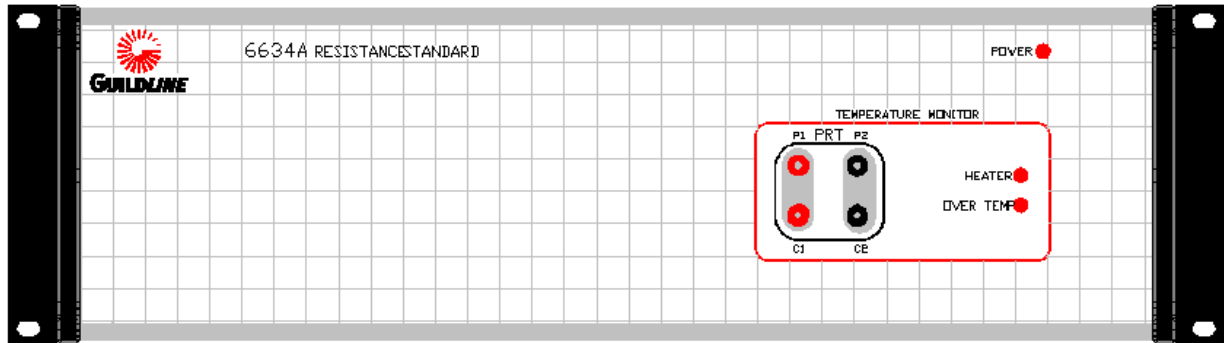

Figure 1-1: Front View

1.3. FRONT PANEL INDICATORS AND CONTROLS

The front panel indicators and controls are illustrated in Figure 1-1. They are provided to indicate power status, heater operation and temperature status.

1.3.1. Power

The POWER indicator is lit when the AC power is applied to the unit and the power ON/OFF switch on the rear panel is “ON”.

1.3.2. Heater

The HEATER indicator is lit when power is being applied to the heater.

1.3.3. Over Temperature

The OVER TEMP indicator is lit when the internal temperature has exceeded $34\text{ }^{\circ}\text{C} \pm 3\text{ }^{\circ}\text{C}$. This may occur when the unit is operated in an ambient temperature in excess of the operating temperature, or in the event of control failure.

1.3.4. PRT

The platinum resistance thermometer, imbedded within the temperature controlled chamber, is configured as a four terminal resistor. The four terminals terminate in four low thermal binding posts labelled “PRT”. The set of terminals consists of two black binding posts for the ‘P1’ and ‘C1’ terminals, and two red binding posts for the ‘P2’ and ‘C2’ terminals of the PRT. The ‘C’ terminals are to be connected to the current source and the ‘P’ terminals are to be connected to the potential measuring circuit of the resistance measuring device. The temperature sensitivity of the PRT is $0.392\text{ }\Omega / ^{\circ}\text{C}$. The resistance at $30\text{ }^{\circ}\text{C}$ is provided in the Report of Calibration. For accurate temperature measurement, the resistance must be measured in four wire mode with an excitation current of 1 mA or less.

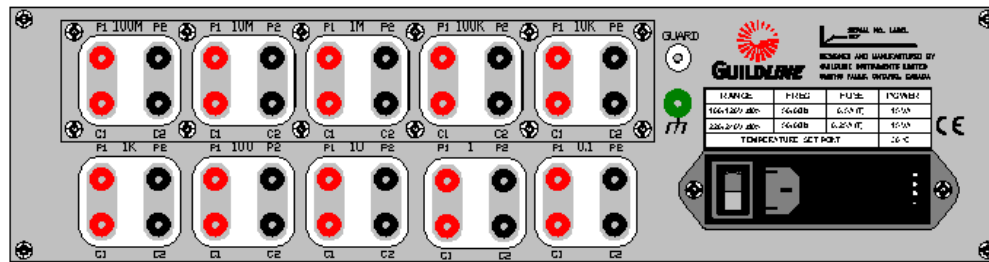

Figure 1-2: Rear View

1.4. REAR PANEL CONNECTORS AND CONTROLS

The rear panel connectors and controls are illustrated in Figure 1-2. They include power entry, resistor terminals and guard/ground terminals.

1.4.1. Line Input Connector

The Line input connector is a combination standard male 3-prong AC connector, power ON/OFF switch and fused line input voltage selector. The line input voltage selector consists of a four-position selector and a fuse holder. The selector allows switching for 100 VAC, 120 VAC, 220 VAC and 240 VAC. A ½ amp time delay fuse is provided for 100/120 VAC operation and a ¼ amp time delay fuse is provided for 220/240 VAC operation.

1.4.2. Resistor Terminals

There are a set of four terminal input/outputs for each installed resistance element. Each set consists of four low thermal binding posts labelled with the nominal value of each of the standard resistors. Each set of terminals consists of two black binding posts for the 'P1' and 'C1' terminals, and two red binding posts for the 'P2' and 'C2' terminals of the specific standard resistor. The 'C' terminals are to be connected to the current source and the 'P' terminals are to be connected to the potential measuring circuit of the resistance measuring device.

1.4.3. Guard Terminal

The GUARD terminal consists of a four-way white binding post. The GUARD terminal is connected to the isothermal chamber which contains the standard resistors. This chamber is isolated from chassis ground and may be guarded through the guard terminal separately from the power ground.

1.4.4. Chassis Ground Terminal

The CHASSIS GND terminal consists of a four-way green binding post. The CHASSIS GND terminal is bonded to the chassis of the model 6634A and to the power ground of the line input connector.

2. SPECIFICATIONS

2.1. GENERAL SPECIFICATIONS

MODEL 6634A RESISTANCE STANDARD General Specifications			
Operating Temperature	+23 ± 5 +73 ± 9	°C °F	
Storage Temperature	-20 to +60 -4 to +140	°C °F	
Operating Humidity (non-condensing)	< 70	% RH	
Storage Humidity (non-condensing)	< 90	% RH	
Temperature Stability (24 hours) (exclusive of the self heating effects of the resistors)	30 ± 0.003	°C	
	86 ± 0.005	°F	
Temperature Stability (1 year) (exclusive of the self heating effects of the resistors)	30 ± 0.01	°C	
	86 ± 0.02	°F	
Cold Power on Stabilization Time to Specified Accuracy	36	hours	
Power Requirements	15	VA	
Voltage Requirements	100, 120, 220 or 240 ± 10%	VAC	
Line Frequency	50 or 60 ± 5%	Hz	
Dimensions (Nominal) (1)	D 503, W 440, H 132 D 19.8, W 17.4, H 5.2	mm in	
Weight	Bench Top	11 24	kg lb
	Rack Mount	9.4 20.7	kg lb

Table 2-1: General Specifications

Notes:

1. The width including rack-mount ears is 480 mm (18.9 in). The height including bench top feet is 142 mm (5.6 in).

2.2. RESISTANCE SPECIFICATION

6634A SPECIFICATIONS					
Nominal Resistance Ω	Nominal Initial Tolerance ² +/- $\mu\Omega/\Omega$ (ppm)	24 Hour Stability +/- $\mu\Omega/\Omega$	12 Month Stability ³ +/- $\mu\Omega/\Omega$	Temperature Coefficient	Maximum Voltage V
0.001 ¹	20	0.4	15	0.04	0.01
0.01 ¹	10	0.2	10	0.02	0.03
0.1	5	0.1	2.5	0.01	0.1
1	5	0.01	2.5	0.005	0.32
10	5	0.01	2.5	0.005	1.0
100	5	0.01	2.5	0.005	3.2
1 k	5	0.01	2.5	0.005	10
10 k	5	0.01	2	0.005	32
100 k	5	0.02	2.5	0.01	100
1 M	10	0.04	4	0.02	320
10 M	20	0.2	5	0.2	1000
100 M	40	0.5	20	0.2	1000

Table 2-2: Resistance Specification

Note 1: Models containing Low Ohms Values are limited to a maximum of 3 elements.

Note 2: Nominal initial tolerance is defined as the maximum variation of resistance mean values as initially adjusted at the point of sale.

Note 3: Stability is exclusive of the effects of applying power above 20 mW, but not exceeding the maximum voltage, in terms of hysteresis and short-term temperature stabilization.

Note 4: Initial 12-month drift is for after the first year of ownership only. The initial 12-month drift is higher due to stabilization of elements. After the initial 24 months, the two-year specification is used as the maximum yearly drift specification.

Calibration Note: Calibrated in air at 23 °C traceable to the SI unit of electric resistance. Calibration uncertainties expanded and expressed at the 95 % level of confidence. An ISO/IEC 17025 accredited certificate and report of calibration stating the calibrated value and estimated uncertainty is provided with each resistor.

3. OPERATING INSTRUCTIONS

3.1. INSTALLATION

The model 6634A has been shipped with the line input voltage set to 240 volts with the fuse removed unless specifically requested to be set to another voltage level. The line input selectors must be set to the correct line voltage before power is applied to the instrument. Remove the warning label positioned across the power cord only after checking the setting of the operating voltage. The line input voltage selection must be set correctly. The settings available are 100 V, 120 V, 220 V, and 240 V. Figure 3-1 details the line input voltage selector setting.

The instrument is supplied with a North American style line cord, unless otherwise specified at time of order. Ensure that the line cord is plugged into a wall socket or extension cord that has a protective or safety ground. Where 3-contact power supply outputs are not available, a suitable protective ground connection must be made before switching the instrument power on. Any interruption of the protective ground may possibly render the instrument unsafe.

To set the correct line input voltage pry open the power receptacle on the rear panel as shown in Figure 3-1.

Place the instrument on a vibration-free bench or install it in an equipment rack as required. Connect the line cord to the appropriate line power outlet and switch the instrument on using the power switch at the back of the instrument at the line input connect.

The red POWER lamp should light, together with the green HEATER lamp.

When the inner chamber containing the standard resistors reaches its operating temperature, the HEATER lamp will indicate periodic cycling. Due to the thermal lagging, it will take several hours to raise the inner chamber and the standard resistors to the operating temperature. The standard resistors should be allowed to stabilize at the operating temperature for at least 36 hours before measurement or use.

3.2. OPERATING NOTES

3.2.1. Connection to Standard Resistors

Connection to the resistor terminals should be made with solid copper wire having low thermal EMF characteristics. The wires to each C-P pair of standard resistor terminals should be twisted and preferably shielded to avoid spurious pick-up. Use Guildline Type SCW Wire or equivalent. The certified resistance of each resistance element and the date of calibration are indicated in the Report of Calibration.

3.2.2. Monitoring of the Internal Temperature

The PRT which comes to the front panel is used to measure the internal temperature. Connect an ohmmeter capable of four wire resistance measurement with low excitation current. Connect the current leads to C1 and C2, and the respective potential leads to P1 and P2. Set the ohmmeter to the best range for measuring $112\ \Omega$ with an excitation

current of 1 mA or less. Measure the resistance of the PRT (R_t). The change in internal chamber temperature from the previously measured resistance value:

$$\Delta t = \left[\frac{(R_t - R_o)}{0.392\Omega} \right] ^\circ C$$

Where R_o is the previously measured resistance value.

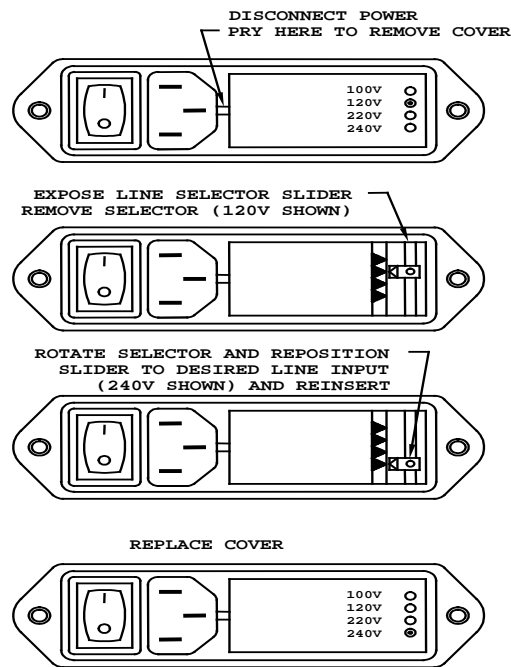

Figure 3-1: Opening the Power Receptacle

Check to see that the fuses inserted in the receptacle correspond to the correct type specified in Section 1.4.1 Line Input Connector

4. MAINTENANCE

4.1. PREVENTIVE MAINTENANCE

4.1.1. Cleaning

The instrument requires very little maintenance other than periodic dusting of the outside of the enclosure. Use alcohol to clean around the standard resistor terminals to avoid formation of leakage paths.

4.1.2. Temperature

Check the internal temperature with the imbedded PRT before using the resistors as references and also periodically.

Compare the calculated temperature with the value given in the Report of Calibration.

4.1.3. Resistor Stability

Resistor stability is determined by comparison against known reference resistors.

4.2. CERTIFICATION OF RESISTANCES

If the resistance of the standard resistors is to be determined by direct comparison with a standards laboratory, the comparison should be made with the resistors inside the enclosure at the operating temperature. After transportation, or if the resistors' temperature stabilized enclosure has been allowed to cool, the resistors should be allowed to stabilize at the operating temperature for at least 36 hours before measurement or before use.

4.3. CORRECTIVE MAINTENANCE

Symptoms appear at the beginning of each of the following paragraphs as a guide to detailed fault location. Refer to Section 5 of this manual for the PRINCIPLES OF OPERATION.

4.3.1. Preliminary Checks

Check POWER indicator - This should be lit when the instrument is connected to the AC line and the power ON/OFF switch is set to "ON". If not, check that both of the other two HEATER and OVERTEMP indicators are also not lit. If they are both not lit, then a general loss of power is indicated. If either indicator is lit, then it indicates that only the power indicator circuit is defective. In addition, check the power outlet. The fuse in the Power Entry module may be blown. It may have been a defective fuse.

Check the HEATER indicator - It should indicate the cycling on and off of the heater.

Check the OVERTEMP indicator - If it is lit, then the temperature inside the enclosure has exceeded $34\text{ }^{\circ}\text{C} \pm 3\text{ }^{\circ}\text{C}$, either from a high ambient temperature or failure of the control circuit. Proceed to paragraph 4.3.3. Check the internal temperature with the

imbedded PRT to compare the calculated temperature with the value given in the Report of Calibration.

4.3.2. Temperature Control

If the temperature is low and the HEATER indicator is lit, check the continuity and resistance of the heater circuit. See drawing M6634A-01-22 for details.

If the temperature is low and the HEATER indicator is lit, check the operation of the control circuit as follows:

- 1) Locate R1 connected from pin C to pin D of P2.
- 2) Short out R1 and the HEATER indicator should light. If not, then check for a fault in the control circuit. If the indicator lights, then check the resistance of R1 and the thermistor pair RT1/RT2. R1 should be 3k ohm to 5k ohm. RT1/RT2 is equal to R1 at 30°C, and is larger than R1 if the temperature is less than 30°C. It has a temperature coefficient of approximately -4%/C°. If necessary, replace R1 and RT1/RT2 as a matched pair.

Control circuit board testing - Measure the voltage at the pins of connector P1 as indicated in Table 4-1.

<u>Between PIN</u>	<u>And PIN</u>	<u>Should Read</u>	<u>Components To Check</u>
20	16	14.0 V 60 Hz	T1
21	16	14.0 V 60 Hz	T1
7	16	-12 V D.C	CR106, CR107
9	7	-3.2 V	see NOTE 1
10	7	-3.2 V	see NOTE 1
12	7	-3.2 V	see NOTE 1
14	7	≈ -0.3 V	when heater off
		-0.7 V	when heater on: see NOTE 2

Table 4-1: Control Circuit Board Testing

NOTE 1: If this reading is incorrect, then check the voltage across C101, 470 μF capacitor. It should read 8.2V ± 5%. If not, then check R107, CR101, CR102 and C101. If correct, then check R102, R105, C103 and Q101.

NOTE 2: If this reading is not obtained, check Q1.

Check the operation of the temperature sensitive oscillator. If the resistance of RT1/RT2 is greater than the resistance of R1, then the oscillator should be running. Check with an

oscilloscope between TP1 (collector of Q102) and Pl-7. The waveform should be as shown. If not, then check the following components:

Q101, Q102, C104, T101, C102, R103, R125, R104, R110

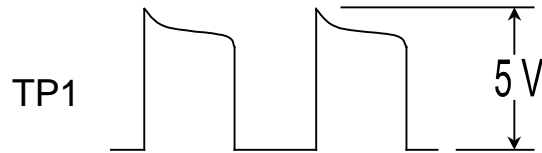

If oscillation is observed, then check between TP2 (collector Q103) and Pl-7. The waveform should be as shown. If not, then check the following components:

Q103, C106, R117, R112, R106

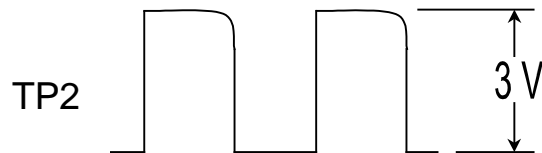

If this waveform is observed, then measure the D.C. voltage between TP3 (CR104 anode) and Pl-7. It should read ≥ -2.5 volts. If not, then check C105, C107, CR103 and CR104. If it is correct, then check Q104, Q105, R121, R122 and R114.

* Indicated waveform typical, if RT1 is at ambient temperature of about 25 °C.

As a further guide to trouble shooting, typical D.C. voltage at the transistor terminals are given in Table 4-2.

DEVICE	VOLTAGE READINGS (P1-7 Common)					
	HEATER ON			HEATER OFF		
	E	B	C	E	B	C
Q101	-3.05	-3.2	-5.2	-3.05	-3.2	-5.2
Q102	-5.4	-5.2	-3.05	-5.4	-5.2	-3.05
Q103	-2.95	-3.05	-5.3	-2.95	-3.05	-5.3
Q104	-1.4	-2.0	-1.45	-----Variable-----		
Q105	-0.75	-1.42	-1.45	-----Variable-----		
Q1	0	-0.75	-0.25	0	≈-0.25	-12.8

Table 4-2: Transistor Voltages

4.3.3. Over Temperature

If the temperature within the constant temperature chamber exceeds $34\text{ }^{\circ}\text{C} \pm 3\text{ }^{\circ}\text{C}$, then the OVER TEMP indicator will be lit. Allow the enclosure to cool to less than $30\text{ }^{\circ}\text{C}$. Check the resistance of R2 ($2.2\ \Omega$). Check between P2-F and P2-H to ensure that the temperature sensitive switch S2 is open. If these conditions are satisfied, then replace fuse F1 and check that the HEATER indicator is lit. Monitor the increase in temperature with the PRT. If the lamp does not indicate heater cycling when the temperature approaches normal, then check the operation of the control circuit as follows:

- Locate pins A and C of P2.
- Short pin A to pin C. The HEATER indicator should go out. If it does, then check the resistances of RT1 and R1 as detailed in section 4.3.2. Replace them as a matched pair. If not, then check at TP1 and TP2 with an oscilloscope (common to P1-7). With P2-A and P2-C shorted, there should be no oscillation. Check the voltage at TP3. It should be zero. Refer to Table 4-2 for voltage measurements to aid in locating the fault in the heater driver.

5. PRINCIPLES OF OPERATION

5.1. INTRODUCTION

The heater control unit in the model 6634A enclosure consists of the following functional blocks.

- a) Temperature Control - consisting of a sensor, oscillator, amplifier, detector and heater.
- b) Over temperature Circuit
- c) Power Supply

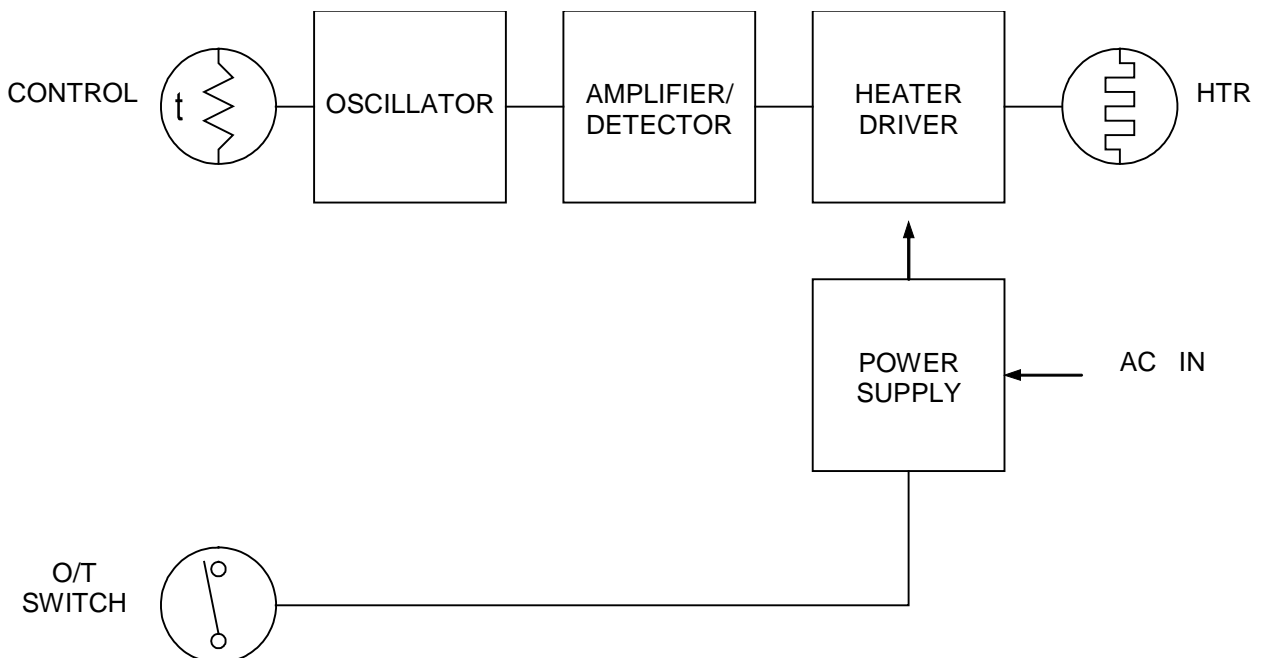

Figure 5-1: HEATER CONTROL UNIT

5.2. TEMPERATURE SENSITIVE OSCILLATOR

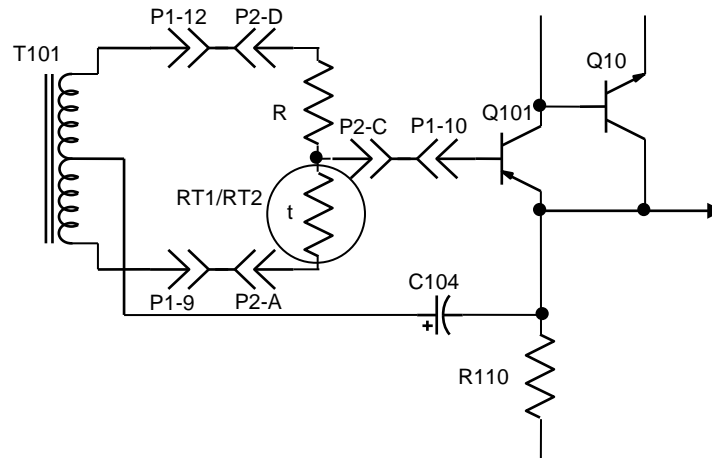

Figure 5-2: TEMPERATURE SENSITIVE OSCILLATOR

Temperature changes are sensed by the thermistor RT1/RT2 connected with R1 across the 1:2 ratio autotransformer T101. As the temperature decreases, the thermistor resistance increases and the voltage divider output to the base of Q101 increases. As soon as this voltage exceeds half the transformer output, the circuit gain becomes greater than one and oscillation occurs.

5.3. AMPLIFIER AND DETECTOR

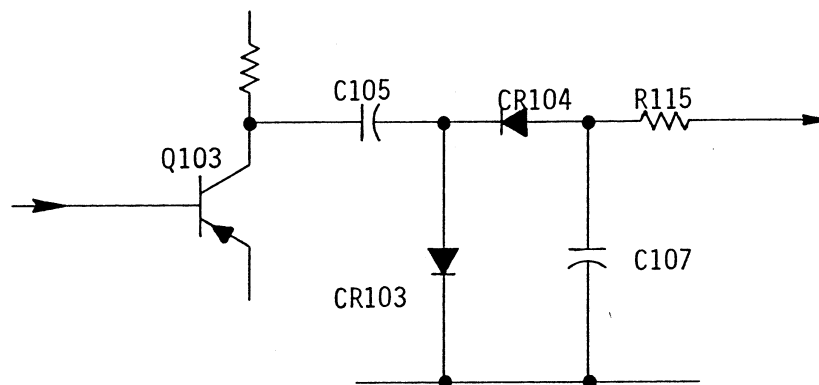

Figure 5-3: AMPLIFIER AND DETECTOR

The output of the oscillator is amplified by Q103 and rectified by a voltage doubler, consisting of C105, CR103, CR104 and C107. The resistor R115 gives current limiting protection for the next stage.

5.4. HEATER DRIVER

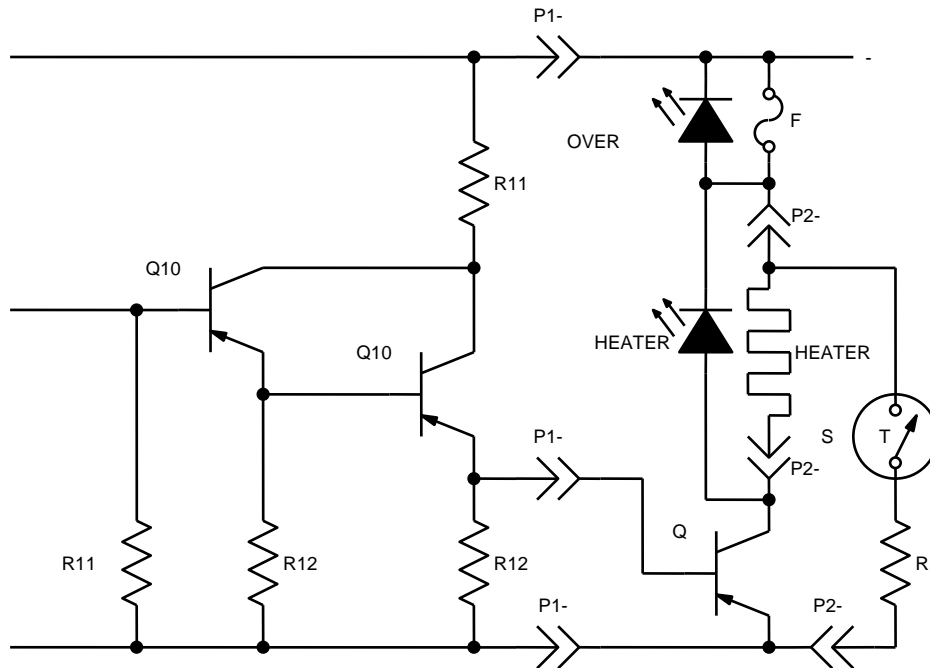

Figure 5-4: HEATER DRIVER

The voltage across C107 causes base current in the emitter follower Q104, which in turn drives another emitter follower Q105. This produces base current to switch on transistor Q1 which controls the heater current. The resistors R119, R121 and R122 ensure that Q1 is not conducting when there is no output from the oscillator.

5.5. OVERTEMPERATURE CIRCUIT

If the temperature in the enclosure exceeds $34\text{ }^{\circ}\text{C} \pm 3\text{ }^{\circ}\text{C}$, switch S2 closes. The load provided by R2 is sufficient to blow the fuse F1 and disconnect all power to the heater.

5.6. POWER SUPPLY

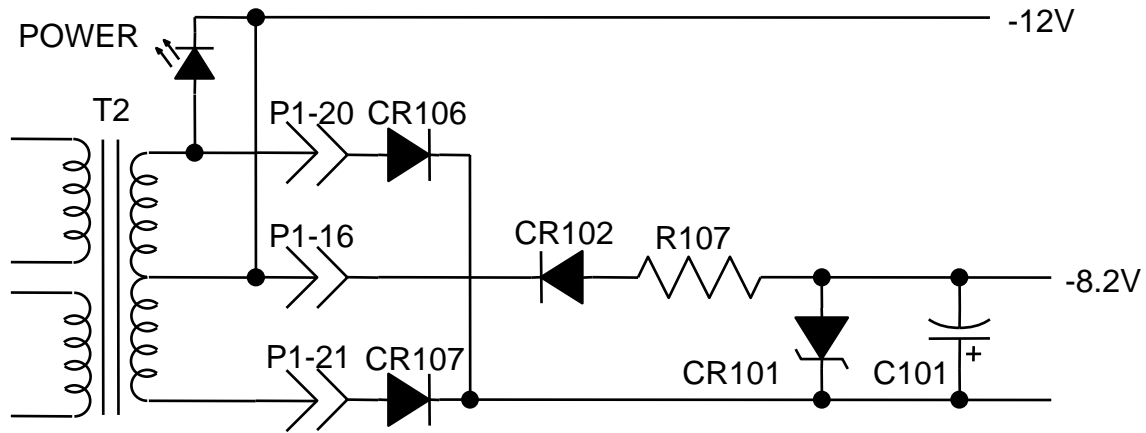

Figure 5-5: POWER SUPPLY

A universal power transformer T2 allows for operation of circuit is fed from a regulator consisting of R107, CR101 and C1 the instrument from 100/120 VAC or 220/240 VAC, 50 or 60 Hz, and feeds a full-wave rectifier. The heater is fed from the unregulated output and the control 01.