

GUILDLINE

INSTRUMENTS

Operation Manual

For The

MODEL 5600

SERIES OF FLUID BATHS

www.guildline.com

NOTICE

The contents and information contained in this manual are proprietary to Guildline Instruments Limited. They are to be used only as a guide to the operation and maintenance of the equipment with which this manual was issued and may not be duplicated or transmitted by any means, either in whole or in part, without the written permission of Guildline Instruments Limited.

**OM5600-K1-00
20 May, 2026**

IMPORTANT NOTE

The 5600 Bath Tank MUST be filled to 5 cm higher than the top spout in the tank prior to turning on the bath. This is to prevent damage to the pump!

TABLE OF CONTENTS

1. INTRODUCTION	1-1
1.1. SCOPE.....	1-1
1.2. GENERAL DESCRIPTION.....	1-1
1.3. OVERVIEW	1-3
1.4. PRINCIPLE OF OPERATION	1-3
2. INSTALLATION	2-1
2.1. PRELIMINARIES	2-1
2.1.1. Unpacking.....	2-1
2.1.2. Power Voltage Selection	2-1
2.1.3. Ground Fault Protection	2-2
2.1.4. Bath Circuit Breaker Information	2-2
2.1.5. Setup and Power On.....	2-3
2.2. 5600 BATH FRONT VIEW	2-4
2.2.1. Control Indicator	2-4
2.2.2. Cool Indicator.....	2-4
2.2.3. Heat Indicator	2-4
2.2.4. USB Connector.....	2-4
2.3. 5600 BATH REAR VIEW	2-5
2.3.1. Line Input Connector	2-5
2.3.2. Laptop Computer Power Connector	2-6
2.3.3. USB Laptop Connector	2-6
2.3.4. Probe Connector	2-6
2.3.5. Cal Connector.....	2-6
3. QUICK SET UP GUIDE	3-1
3.1. TEMPERATURE CONTROL OPERATION GUIDE	3-1
4. USER INTERFACE	4-1
4.1. MAIN SCREEN	4-3
4.1.1. Adjust Offset	4-3
4.1.2. Exit.....	4-4
4.1.3. Enable Remote	4-4
4.1.4. Run Pattern	4-4
4.1.5. Set Point.....	4-4
4.1.6. Log Data	4-4
4.1.7. Setup	4-4

4.2.	SET POINT SCREEN	4-5
4.2.1.	Cancel	4-5
4.2.2.	OK.....	4-5
4.3.	RUN PATTERN SCREEN	4-6
4.3.1.	Filename	4-6
4.3.2.	Title	4-6
4.3.3.	Unit	4-7
4.3.4.	Pattern Length [HH:MM]	4-7
4.3.5.	Cancel	4-7
4.3.6.	Run.....	4-7
4.4.	SETUP GUI SCREEN	4-8
4.4.1.	Data Logging Interval	4-8
4.4.2.	Detailed Graph Length	4-8
4.4.3.	Close	4-8
4.4.4.	Apply	4-8
4.5.	SETUP CONTROLLER SCREEN	4-9
4.5.1.	Unit	4-9
4.5.2.	State	4-10
4.5.3.	Size.....	4-10
4.5.4.	Cancel	4-10
4.5.5.	Apply	4-10
4.6.	SETUP COMMS SCREEN	4-11
4.6.1.	Incoming Interface	4-11
4.6.2.	Connection Timeout.....	4-11
4.6.3.	Outgoing Interface.....	4-12
4.6.4.	Serial Port/GPIB Address/ IP Address	4-12
4.6.5.	Communication Timeout	4-12
4.6.6.	Close	4-12
4.6.7.	Apply	4-12
4.7.	PASSWORD SCREEN.....	4-13
4.7.1.	Cancel	4-13
4.7.2.	OK.....	4-13
4.8.	SETUP CONTROLLER SCREEN	4-14
4.8.1.	Window	4-14
4.8.2.	Kp.....	4-14
4.8.3.	Ki	4-15
4.8.4.	Threshold.....	4-15
4.8.5.	Cooling On	4-15
4.8.6.	Cooling Off.....	4-15
4.8.7.	Heat Delay	4-15
4.8.8.	Booster On.....	4-15
4.8.9.	Booster Off.....	4-15
4.8.10.	Close	4-15
4.8.11.	Apply	4-15

4.9.	CAL SENSOR SCREEN.....	4-16
4.9.1.	Control and Auxiliary S/N	4-16
4.9.2.	A, B, and C Thermistor Coefficients	4-17
4.9.3.	Close	4-17
4.9.4.	Apply	4-17
4.10.	CAL CHANNEL SCREEN.....	4-18
4.10.1.	C0, C1, and C2 Linearization Coefficients.....	4-18
4.10.2.	Close	4-18
4.10.3.	Apply	4-18
5.	REMOTE CONTROL	5-1
5.1.	INTERFACES	5-1
5.2.	IEEE-488 (GPIB) INTERFACE	5-1
5.2.1.	CONTROLLER	5-2
5.2.2.	IEEE-488 RESPONSES	5-2
5.2.3.	INTERCONNECTING CABLE AND IEEE-488 CONNECTOR.....	5-2
5.2.4.	TYPICAL SYSTEM	5-2
5.2.5.	ADDRESS AND TALK/LISTEN SELECTION	5-3
5.2.6.	IEEE-488 ELECTRICAL INTERFACE.....	5-3
5.2.7.	IEEE-488 INPUT BUFFERING	5-5
5.2.8.	IEEE-488 OUTPUT BUFFERING	5-5
5.2.9.	IEEE-488 DEADLOCK.....	5-5
5.3.	RS-232C INTERFACE.....	5-6
5.3.1.	RS-232C RESPONSES.....	5-6
5.4.	COMMAND LANGUAGE	5-7
5.4.1.	GENERAL SYNTAX FOR COMMANDS.....	5-7
5.4.2.	GENERAL SYNTAX FOR NUMBERS.....	5-7
5.5.	REMOTE AND LOCAL OPERATION.....	5-8
5.5.1.	LOCAL.....	5-8
5.5.2.	LOCAL WITH LOCKOUT.....	5-8
5.5.3.	REMOTE.....	5-8
5.5.4.	REMOTE WITH LOCKOUT	5-9
5.6.	PROGRAMMING COMMAND SUMMARY	5-9

5.7.	REMOTE COMMANDS	5-13
5.7.1.	*CLS - CLEAR STATUS COMMAND	5-13
5.7.2.	*ESE <u> - SET EVENT STATUS ENABLE REGISTER	5-13
5.7.3.	*ESE? - EVENT STATUS ENABLE QUERY	5-13
5.7.4.	*ESR? - EVENT STATUS REGISTER QUERY	5-13
5.7.5.	*IDN? - IDENTIFICATION QUERY	5-14
5.7.6.	*OPC - OPERATION COMPLETE	5-14
5.7.7.	*OPC? - OPERATION COMPLETE QUERY	5-14
5.7.8.	*OPT? - REPORT AVAILABLE OPTIONS	5-15
5.7.9.	*RST - DEVICE RESET	5-15
5.7.10.	*SRE <u> - SERVICE REQUEST ENABLE COMMAND	5-16
5.7.11.	*SRE? - SERVICE REQUEST ENABLE QUERY	5-16
5.7.12.	*STB? - STATUS BYTE QUERY	5-16
5.7.13.	*TST? - QUERY RESULTS OF SELF TEST	5-16
5.7.14.	*WAI - WAIT-TO- CONTINUE COMMAND	5-16
5.7.15.	CONFigure: - SET OPERATING CONFIGURATION	5-17
5.7.15.1.	CONFigure:BOOSter?	5-17
5.7.15.2.	CONFigure:COOLing?	5-18
5.7.15.3.	CONFigure:HEATer?	5-18
5.7.15.4.	CONFigure:WINDow <window>	5-18
5.7.15.5.	CONFigure:WINDow?	5-18
5.7.15.6.	CONFigure:SETPoint <setpoint>	5-18
5.7.15.7.	CONFigure:SETPoint?	5-18
5.7.15.8.	CONFigure:SETUp	5-19
5.7.15.9.	CONFigure:SETUp?	5-19
5.7.16.	FETCh - MEASUREMENT DATA QUERY	5-19
5.7.16.1.	FETCh? <channel>	5-20
5.7.16.2.	FETCh:DIFFerence?	5-20
5.7.16.3.	FETCh:HISTory?	5-20
5.7.17.	MEASure - SET/DISPLAY THE MEASUREMENT PARAMETERS	5-21
5.7.17.1.	MEASure:CALCulation <mode>	5-22
5.7.17.2.	MEASure:CALCulation?	5-22
5.7.17.3.	MEASure:FILTer <state>,<function>,<size>	5-22
5.7.17.4.	MEASure:FILTer?	5-22
5.7.17.5.	MEASure:HISTory <state>,<rate>,<mode>	5-23
5.7.17.6.	MEASure:HISTory?	5-23
5.7.17.7.	MEASure:HISTory:CLEAr	5-23
5.7.17.8.	MEASure:SENSor <channel>,<sensor>	5-23
5.7.17.9.	MEASure:SENSor? <channel>	5-23
5.7.17.10.	MEASure:TREND <channel>	5-24
5.7.17.11.	MEASure:TREND? <channel>	5-24
5.7.17.12.	MEASure:UNIT <unit>	5-24
5.7.17.13.	MEASure:UNIT?	5-24
5.7.18.	SOFcAL - SET 5600 CALIBRATION COEFFICIENTS	5-25
5.7.18.1.	SOFcAL:CHANnel<channel>,<C0>,<C1>,<C2>	5-25
5.7.18.2.	SOFcAL:CHANnel? <channel>	5-25
5.7.18.3.	SOFcAL:DATE <YYYY>,<MM>,<DD>	5-25
5.7.18.4.	SOFcAL:DATE?	5-26
5.7.18.5.	SOFcAL:SENSor <sensor>,"s", S, a, b	5-26
5.7.18.6.	SOFcAL:SENSor? <sensor>	5-26

5.7.19.	SYSTem: - SET THE 5600 OPERATING PARAMETERS	5-26
5.7.19.1.	SYSTem:COMMunicate:GPIB <address>,<mode>	5-28
5.7.19.2.	SYSTem:COMMunicate:GPIB?	5-28
5.7.19.3.	SYSTem:COMMunicate:SERial	5-28
5.7.19.4.	SYSTem:COMMunicate:SERial?	5-29
5.7.19.5.	SYSTem:DATE <YYYY>,<MM>,<DD>	5-29
5.7.19.6.	SYSTem:DATE?	5-29
5.7.19.7.	SYSTem:DIAGnostic:ROMChecksum?	5-30
5.7.19.8.	SYSTem:DIAGnostic:SerialNUMber <number>	5-30
5.7.19.9.	SYSTem:DIAGnostic:SerialNUMber?	5-30
5.7.19.10.	SYSTem:DIAGnostic:TEST? <number>	5-30
5.7.19.11.	SYSTem:LOCAL	5-30
5.7.19.12.	SYSTem:LOCKOUT	5-31
5.7.19.13.	SYSTem:REMOTE	5-31
5.7.19.14.	SYSTem:TERSe	5-31
5.7.19.15.	SYSTem:TIME <hh>,<mm>,<ss>	5-31
5.7.19.16.	SYSTem:TIME?	5-31
5.7.19.17.	SYSTem:VERBose	5-31
5.7.19.18.	SYSTem:VERSion?	5-31
6.	TROUBLESHOOTING, MAINTENANCE AND CHECKS	6-1
6.1.	INTRODUCTION	6-1
6.1.1.	Model 5600 Oil Recommendation	6-1
6.1.2.	Maintenance	6-1
6.1.3.	Maintenance Guidelines and Schedule	6-2
6.1.4.	Error Messages	6-2
6.1.5.	Cleaning Guidelines	6-3
6.2.	TANK DRAIN	6-4
6.3.	TROUBLESHOOTING	6-4
6.4.	OVER TEMPERATURE RESET	6-6
6.5.	HEATER REPLACEMENT	6-7
7.	APPENDICES	7-1
7.1.	GENERAL SPECIFICATIONS	7-1
7.2.	TEMPERATURE CALCULATION	7-3
7.2.1.	THERMISTOR	7-3

LIST OF FIGURES

FIGURE 1-1 : MODEL 5600 FLUID BATH..... 1-4
FIGURE 1-2 : MODEL 5600 FLUID BATH (300L SHOWN) 1-4
FIGURE 2-1: 5600 BATH FRONT VIEW 2-4
FIGURE 2-2 : 5600 BATH REAR VIEW 2-5
FIGURE 4-1 : USER INTERFACE NAVIGATION DIAGRAM..... 4-2
FIGURE 5-1 : EVENT STATUS BIT OPERATION 5-12
FIGURE 6-1 : HEATER REPLACEMENT 6-8

LIST OF TABLES

TABLE 2-1 : VOLTAGE AND CIRCUIT BREAKER RATINGS.....	2-2
TABLE 5-1 : IEEE-488 DEVICE CAPABILITIES.....	5-3
TABLE 5-2 : IEEE-488 PIN DESIGNATIONS.....	5-4
TABLE 5-3 : RS232 PIN DESIGNATIONS.....	5-6
TABLE 5-4 : REMOTE/LOCAL STATE TRANSITIONS	5-9
TABLE 5-5 : EVENT STATUS REGISTER	5-14
TABLE 5-6 : STATUS BYTE REGISTER	5-17
TABLE 6-1 : MAINTENANCE SCHEDULE	6-2
TABLE 7-1 : GENERAL SPECIFICATIONS.....	7-1
TABLE 7-2 : MODEL SPECIFICATIONS.....	7-2

1. INTRODUCTION

1.1. SCOPE

This document describes the installation, operation, specifications, and maintenance information for the Guildline Instruments Limited 5600 Series of High Precision Variable Temperature Fluid Baths.

1.2. GENERAL DESCRIPTION

The 5600 Series of Fluid Baths are highly accurate and stable baths for use with water, salt water, mineral oil, alcohol, ethylene glycol and fluorocarbons. It employs two high stability thermistor type resistance thermometers, for control and temperature monitoring of the bath fluid. The control panel consists of a touch screen windows computer which provides for complete control of programming the bath operation and monitoring the temperature stability. The temperature range is from 0 °C to 55 °C with a resolution of 0.0001 °C and ± 0.001 °C stability. For temperatures below 5 °C glycol or other antifreeze must be added to the water.

Note that the Bath is configured separately for use with oil or water so when ordering specify ‘/O’ or ‘/W’ for setup respectively for Oil or Water.

Uses for the 5600 Series Fluid Baths include:

- Maintaining a constant temperature environment for reference standards.
- Automated calibration of resistance-temperature devices or thermometers.
- Calibration of underwater instruments.
- Thermal stressing of materials.

In addition to the laptop computer display controls, the bath functions can be controlled via the USB interface or an IEEE adaptor. Remote control commands include monitoring the fluid temperature as well as modifying the temperature set point.

The tank portion of the bath is reinforced fiberglass with built-in proprietary EMI shielding. The circulation pump, cooling unit and electronic hardware are located in a separate area beside the tank to provide full and unimpeded access to the bath chamber. For the 300 litre model the circulation pump, cooling unit, and electronic hardware are located in a separate mechanical control unit that connects to a separate tank bath unit via insulated hoses. Having the 300 litre model designed as two separate physical units allows the 5600-300 Fluid Bath to go onto an elevator and through a regular door. A clear plastic, EMI shielded, tank cover is supplied with each unit.

The 5600 series of baths consists of three models with bath tanks of reinforced fiberglass. The models are designated as follows:

- Model 5600-75L - bath with 75 litre fiberglass tank
- Model 5600-100L - bath with 100 litre fiberglass tank
- Model 5600-300L - bath with 300 litre fiberglass tank

The Baths are configured separately for use with Water or Oil with designations as follows:

- Model 5600-xxL/O - bath configured for use with mineral oil
- Model 5600-xxL/W - bath configured for use with water, salt water, or other fluid

Normally the maximum bath temperature is limited by software within the bath control circuitry, however in order to avoid overheating in the case of circuit malfunction a temperature limit switch is used as backup protection. This switch will shut down the entire bath if the fluid temperature exceeds $60\text{ }^{\circ}\text{C} \pm 4\text{ }^{\circ}\text{C}$. The switch will automatically reset once the fluid temperature has cooled down below $55\text{ }^{\circ}\text{C}$.

1.3. OVERVIEW

The 5600 Series of High Precision Variable Temperature Fluid Baths consists of models with temperature controlled bath tank sizes of 75, 100 and 300 litre capacity. Note that no stirrers or propellers are used with the 5600 Series so the entire bath interior is available for use. The tank construction is reinforced fiberglass material which is chemically inert and perfect for profiling various liquids over a temperature range. The inside of the tank is coated with a special gelcoat designed to be 'slippery' to avoid disruptions in fluid flow. In addition the fiberglass tank contains proprietary EMI shielding to protect contents from electrical and magnetic emissions.

The bath construction includes a fluid pump, a small cooling refrigerant unit, control and booster heaters, and heat exchanger - all controlled through a touch screen windows laptop computer.

No adjustments of the 5600 series of baths are required other than setting up the temperature control and monitoring parameters required for proper operation. A separate temperature probe is provided that can be placed anywhere in the bath so that the exact fluid temperature may be monitored. The auxiliary temperature probe can be used instead of a separate external digital thermometer and has the advantage of being integrated with the bath's user interface.

1.4. PRINCIPLE OF OPERATION

The design of the bath uses a fixed rate of cooling from an R134a refrigerant compressor-condensing unit and balances this to the heating/cooling level required by rapidly controlling a heater duty cycle to provide the exact heating/cooling required to balance the heat losses to ambient.

A variable flow rate circulation pump forces the fluid through a heat exchanger which combines the heat transfer from the fixed cooling unit and the variable duty cycle heaters such that the flow of fluid entering the bottom of the chamber is kept at a fixed temperature as determined by the set point entered into the controller. The touch screen windows laptop computer controls all functions of the bath as the control parameters are entered by the operator through the touch screen of the computer or through the USB interface of the computer.

A stable thermistor probe is used to monitor and control the temperature of the fluid. A 2nd auxiliary thermistor probe is used to monitor the exact fluid temperature anywhere in the bath chamber. This provides a means of independently monitoring the stability and accuracy of the temperature control system, and the fluid inside the bath chamber. Fluid / oil baths provided by other manufacturers typically require a third-party thermometer to provide the real temperature of the fluid in the bath. This is not required with the 5600 Fluid Bath Series.



Figure 1-1 : Model 5600 Fluid Bath (75 L and 100 L models are same size)



Figure 1-2 : Model 5600 Fluid Bath (300L)

2. INSTALLATION

2.1. PRELIMINARIES

2.1.1. Unpacking

- a. Remove the 5600 Fluid Bath and the other items from the shipping container(s) to a suitable location.
- b. The following items are included with each new unit
 - i. Operation Manual, (OM5600)
 - ii. One Laptop Computer complete with power supply line cord, (GPN 33320-01-17)

Note that because of international aviation rules related to the shipment of laptop computer batteries, the Laptop Computer will be supplied by the local distributor
 - iii. One Computer USB connection cable, (GPN 250-04060)
 - iv. 120 VAC Line Cord, (GPN 250-04025), or
220 VAC Line Cord, (GPN 250-04027)
 - v. Clear polycarbonate cover, (GPN 31701-01-11)
 - vi. Temperature Probe, (GPN 30059-02-21)

2.1.2. Power Voltage Selection

The 5600 Fluid Baths are equipped with circuit breaker type power entry connectors and power switches. Each bath is configured at the factory for the voltage and frequency specified at the time of ordering. The baths set for 120 VAC operation are equipped with a 15 A circuit breaker and baths set for 220 VAC operation are equipped with a 10 A circuit breaker.

The laptop computer is equipped with a universal voltage power supply and line cord.

It is imperative that the voltage markings at the power entry area at the back of the bath match the power source voltage. If the markings do not agree contact Guildline Instruments Limited for instructions before connecting the power to the bath.

Where the molded plugs on the line cords supplied with the instrument do not match the local power outlet socket, the plug can be removed and replaced with one that does fit the local service. The plug should be re-wired as follows:

- | | | |
|--------------|---|-----------------|
| Brown wire | - | Line input |
| Blue wire | - | Neutral input |
| Green/Yellow | - | Ground (safety) |

2.1.3. Ground Fault Protection

The electrical circuits of the 5600 bath are isolated from the line voltage through an isolation transformer. If an ECLB, (Earth Leakage Circuit Breaker) is to be used it must be a Type B device and must be suitable for protecting equipment with a DC component in the leakage current.

2.1.4. Bath Circuit Breaker Information

Table 2-1 below indicates the power source voltage ranges and circuit breaker ratings of 5600 models.

VOLTAGE AND CIRCUIT BREAKER RATINGS	
5600 - 120	5600 - 220
115 VAC \pm 10 %, 15 A	220 VAC \pm 10 %, 10 A

Table 2-1 : Voltage and Circuit Breaker Ratings

**Note: No external line voltage/frequency selection is required for power entry.
Only the source voltage must match the name plate rating of the bath.**

2.1.5. Setup and Power On

- a. Verify that the power switch is off.
- b. Remove any excess packing material from the bath that is provided for shipping purposes only.
- c. Verify that the voltage markings at the power entry area at the back of the bath match the power source voltage.
- d. Connect the input power cord from the 5600 Bath to the AC power outlet.
- e. Set the laptop computer in a suitable location and connect the USB port of the computer to the USB port on the back of the 5600 Bath. Note that it is recommended not to put the laptop computer on top of the bath.
- f. Connect the laptop computer power supply from the computer power input connector to the AC power outlet. Ensure the 5600 control software is installed on the laptop computer.
- g. For the 5600-300L model connect the Control unit to the Bath unit via the provided hoses.
- h. Fill the bath with the fluid to be used up to a minimum of 5 cm above the top pump inlet port. Note that the 5600 Bath is optimized at the factory for use with mineral oil or water.
- i. Insert the separate temperature probe into the bath fluid to provide exact temperature of the fluid. Note that the probe should not be fully immersed and there is a holder for the probe built into the bath cover. An optional bracket, Model 56001-2 (31659-02-11) for 75/100 L and Model 56001-3 (31659-03-11) for 300 L is available from Guildline which allows the temperature probe to be placed anywhere in the bath.

Warnings: 1. Do not power on the 5600 Bath without any fluid in the bath chamber as this will destroy heaters and damage the circulation pump.

2. To use the bath with water below 8 °C the water must be mixed with antifreeze such as ethylene glycol or the heat exchanger will freeze up.

3. Do not operate the bath above 15 °C when using ethylene glycol as the fumes can be hazardous.

4. Do not fully submerge the bath temperature probe.

- j. Turn on the power switch to the 5600 Bath and press the power button of the laptop computer. You should see the computer display panel light up and hear the circulation pump turn on.
- k. The 5600 Bath should now be ready to use. Refer to Section 3 to complete a functional test of the 5600 Bath.

2.2. 5600 BATH FRONT VIEW

There are no controls on the front panel of the 5600 Bath or on the separate Control unit for the 5600-300L Model; only indicators for the Booster Heater and the Cooler as well as the PID control. The user interface to the bath is provided via a touch screen laptop computer which is described in Section 3. There is also a convenient USB port to access the data from the laptop computer controller.

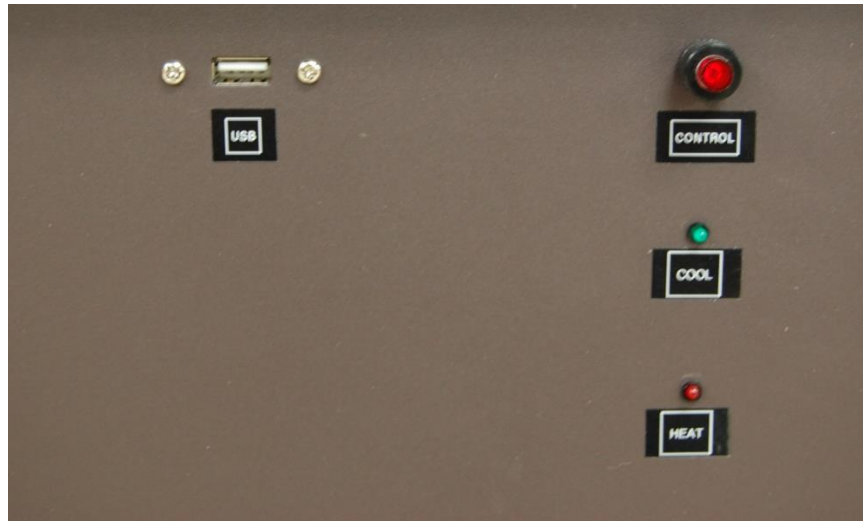

Figure 2-1: 5600 BATH FRONT VIEW

2.2.1. Control Indicator

The **Control Indicator** indicates that the bath is regulating temperature. It is a smaller heater used to fine tune the temperature set point and maintain stability. It will be off when the bath has to cool to reach the desired set point; and be on full when heating to a higher temperature set point. Once at the desired set point you will notice the light will flicker to regulate the bath temperature.

2.2.2. Cool Indicator

The green LED on the front indicates when the **compressor** is operating to **cool** the bath.

2.2.3. Heat Indicator

The red LED on the front indicates when the **booster heater** is operating to **heat** the bath.

2.2.4. USB Connector

The USB connector provides a convenient way to copy stored data off the Laptop PC controller.

2.3. 5600 BATH REAR VIEW

At the rear of the 5600 Fluid Bath, or rear of the separate 5600-300 Control Unit, there is a user service door for basic maintenance and tank drain valve access. Also on the door are connectors for the Auxiliary Bath Probe as well as control channel calibration access. There is also the connection for the laptop computer USB and AC Power.



Figure 2-2 : 5600 BATH REAR VIEW

Caution:

It is essential that the AC Power is disconnected when opening the user service door to minimize the risk of electric shock.

2.3.1. Line Input Connector

The **Line Input Connector** is a 3-prong AC standard male connector. A separate combination ON/OFF switch and circuit breaker is provided above the line input connector. The line input connector accommodates nominal voltages of 120 V and 220 V. A 15 A circuit breaker is provided for the 120 V operation and a 10 A circuit breaker is provided for the 220 V operation.

2.3.2. Laptop Computer Power Connector

The **Laptop Computer Power Connector** is a 3-prong AC standard female connector. This connector provides an isolated 120 V AC power output for the Laptop power supply.

2.3.3. USB Laptop Connector

The USB computer connector is how the laptop computer connects to the bath. The computer controls the functions of the bath through this USB communication link.

2.3.4. Probe Connector

The Probe Connector is where the bath auxiliary probe can be connected. The Auxiliary probe can be used to monitor any point in the fluid bath or even ambient temperature. It is a calibrated thermistor PRT which typically is used in the PRT rest hole provided in the lid of the bath. The auxiliary probe is not mandatory for the bath to operate but is very useful for monitoring the temperature of the bath to traceable thermometry units.

2.3.5. Cal Connector

The Cal Connector allows access to the control channel of the bath so that a calibration can be performed. There is a 7-pin plug that **MUST** remain in the connector at all times during normal bath operation.

3. QUICK SET UP GUIDE

3.1. TEMPERATURE CONTROL OPERATION GUIDE

Step 1) Unpack the fluid bath and visually inspect for physical damage. Once complete unpack the laptop computer and connection cables. For the 5600-300L model connect the Control Unit to the Bath Unit via the provided flexible hoses.

Step 2) Fill up the fluid bath with water, oil, or other desired liquid. **DO NOT turn on the actual bath until there is sufficient fluid inside to submerge both holes on the sidewall of the bath chamber.**

Step 3) Connect the USB cable from the laptop computer to the rear of the fluid bath as well as the power for the computer and fluid bath. Then turn on the laptop computer.

Step 4) If using the Auxiliary Probe, connect it to the 5 pin connector on the rear of the bath and ensure the termination plug is also plugged into the 7 pin connector in the rear of the bath.

Step 5) Once the computer is powered up, power on the main switch at the back of the fluid bath. The fluid should begin to flow and the compressor should also turn on and will be audible.

Step 6) Now run the 5600 fluid bath control software which has been pre-loaded into the Windows laptop computer. You will be greeted with the main screen shown below. If using the Auxiliary Probe it should begin to report on the graph of the main screen window as well as the set point and other statistical data.

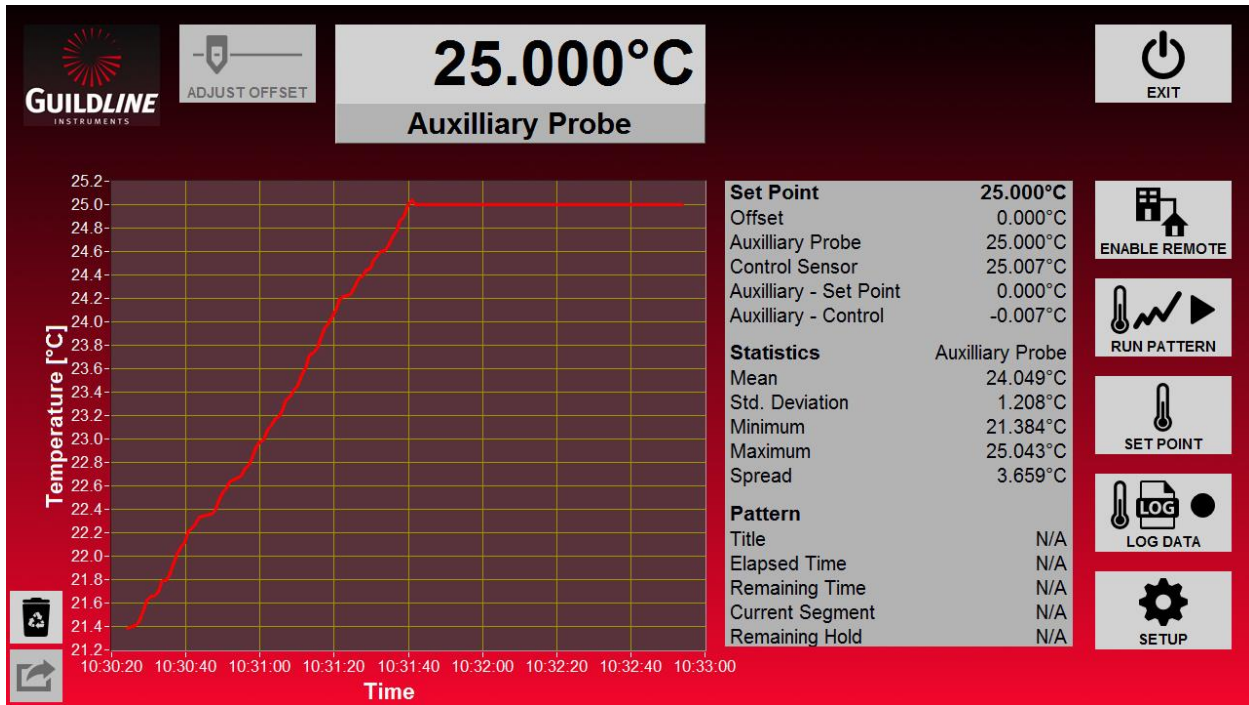

Step 7) If the bath does not report temperature and you are using an Auxiliary Probe then you will need to enter the "Setup" window using the "Setup" button located at the bottom right of the main screen. Ensure the "Setup" is as shown below and then use the "Serial Port" drop menu to select the COM port available to the system or refresh if one is not shown.

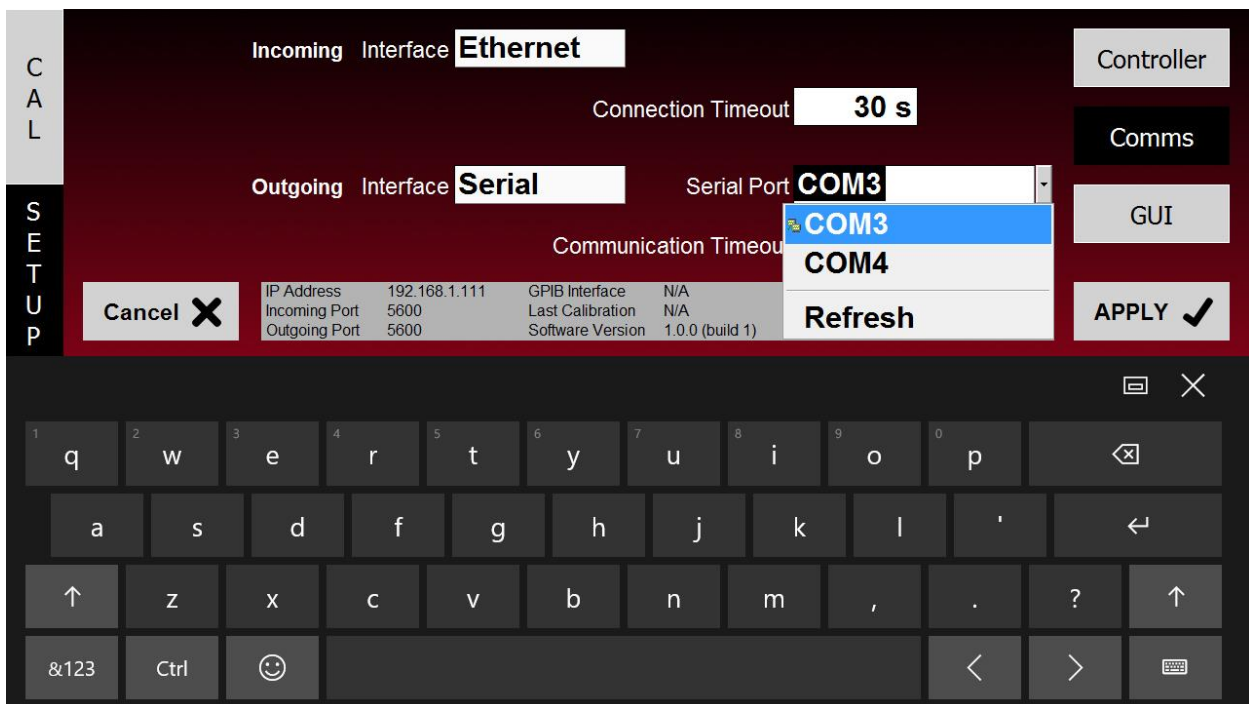

Note that the 5600 fluid bath can also use an internal GPIB interface in which case use “GPIB Instrument” from the same drop down menu. You can switch between Serial and GPIB with the “Outgoing Interface” selection.

Step 8) Once selected "Apply" the changes then "Exit". The temperature of the Auxiliary Probe should begin to report on the graph of the main screen window as well as the set point and other statistical data.

4. USER INTERFACE

The 5600 Graphical User Interface (or GUI) is provided on a Windows laptop computer which is connected to the bath hardware via a standard USB Cable. The interface utilizes the touch screen interface with on screen keyboard for user control and entry. The Fluid Bath user interface software utilizes the full screen as a “Metro” style application common to Windows 8 and newer. Note that this interface runs on Professional (x86 and x64) versions of windows and is not supported in RT versions.

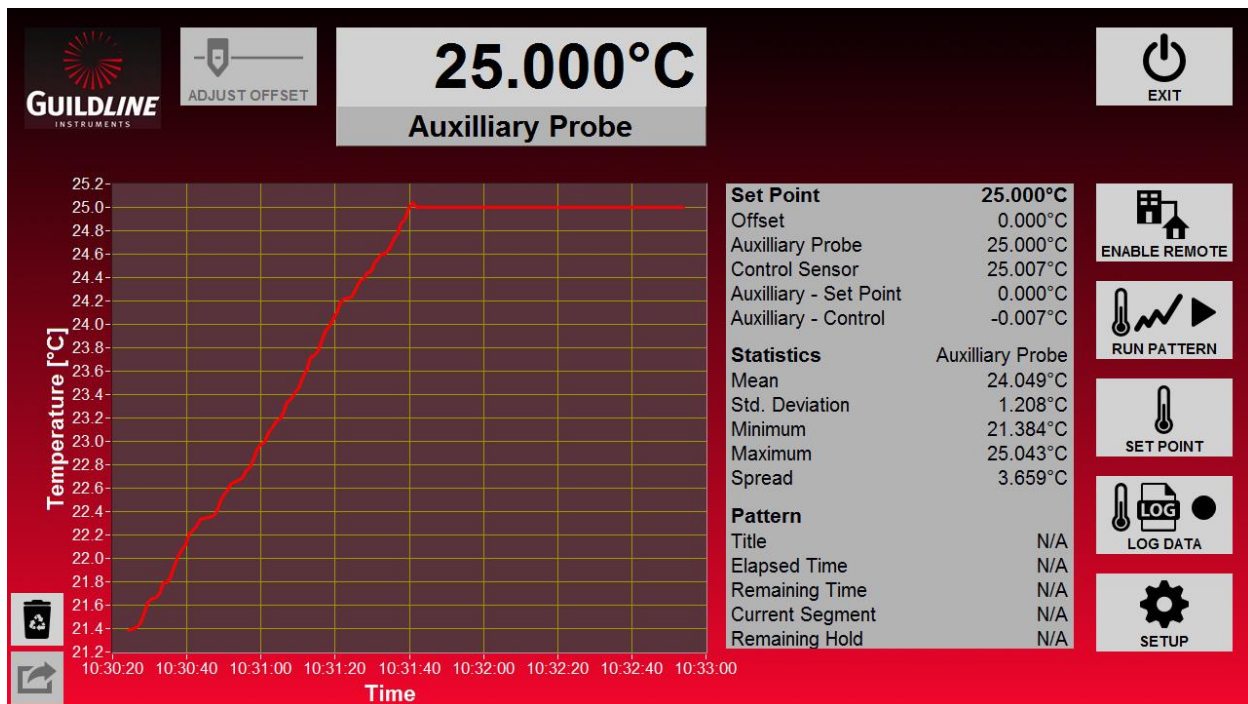

The GUI consists of the main screen and various set up and configuration screens for controlling the temperature of the Fluid Bath and setting the calibration constants of the bath. On the following page is a full navigation/hierarchy map of the software screens.

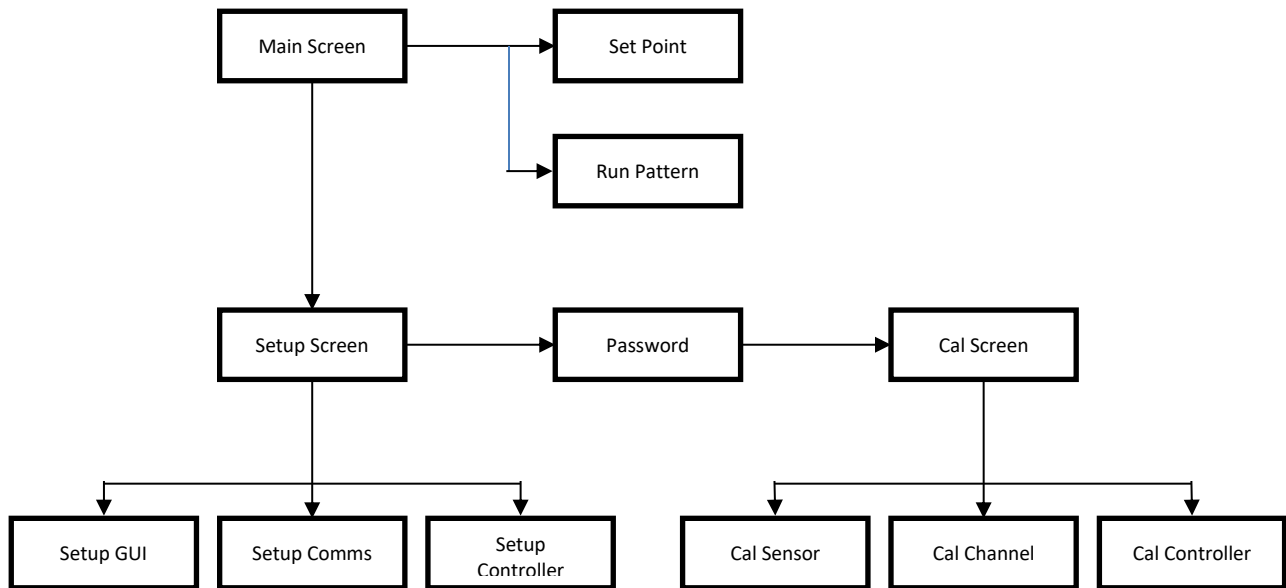

Figure 4-1 : User Interface Navigation Diagram

As shown in the diagram above all screens can be easily accessed starting from the main screen, with the exception of the screens which affect the calibration and temperature control of the 5600 Fluid Bath. These screens are password protected. The default password for these screens is “Guildline” and can be altered by changing the stored password in the “FluidBath5600.ini” file stored in the program directory under the key “Password”.

Also note that this interface can be installed and run on any computer running Windows 7 or newer and can run as a standard desktop app “Windowed”, rather than full screen “Metro” mode by changing the “TabletPC” from true to false in the “FluidBath5600.ini” file.

Note that to edit the FluidBath5600.ini file you will need administrative privileges in Windows.

4.1. MAIN SCREEN

The main screen of the user interface is where you have access to all user features of the 5600 Fluid Bath. The screen has operator functions available mainly to the right hand side of the screen with statistics in the middle of the screen and graph to the left. The graph will automatically adjust the scale such that all data will be visible up to a maximum length of hours as defined in the Setup GUI screen. If data is being logged all data is still available in a storage file on the Windows laptop computer controller.

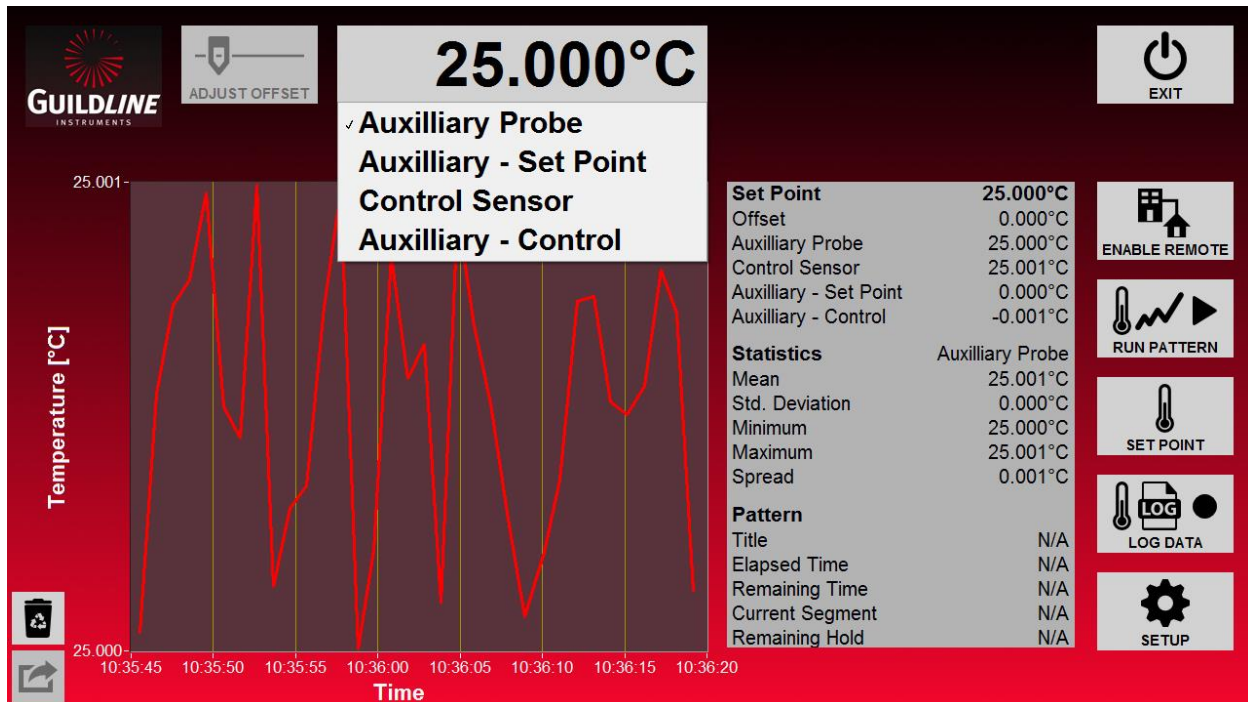

The data on the graph can be cleared by touching the “Trash Bin” icon to the bottom left of the screen. Note that clearing the graph does not remove the data from the stored data if “Log Data” is enabled. Also note that the statistics will be cleared as well. These statistics reflect all the present data in the graph.

The chart can display any of several different traces relating to the Control and Auxilliary probes (sensors) which can be accessed by the drop menu right below the large reading display.

4.1.1. Adjust Offset

The “Adjust Offset” button is a tool to make minor adjustments to the Set Point to enable the temperature control to be more accurate. This functionality uses the “Auxilliary Probe” (i.e. actual temperature of the bath fluid) rather than the native Set Point Accuracy (i.e. control temperature for the heat exchanger).

4.1.2. Exit

The “Exit” button simply exits the 5600 Fluid Bath Graphical User Interface. The 5600 Fluid bath will continue to maintain the temperature of the last configured Set Point even if the GUI is not running.

4.1.3. Enable Remote

The “Enable Remote” button disables all interactive features of the GUI and allows the 5600 Fluid Bath to be controlled by another computer via USB, RS-232C, GPIB, or over the network with TCP/IP. Any one of these options can be used at any time. Note that there is no built in RS-232C or GPIB within the laptop computer, however there are commercially available adapters for the built in USB which can be obtained from Guildline Instruments. While remote is enabled the GUI will still display the graph, statistics and temperature reading.

4.1.4. Run Pattern

The “Run Pattern” button opens a screen which allows the operator to set up a sequence where the set point can be changed to a user defined value and maintained for a user defined time. This tool helps simplify and automate temperature profiling the contents of the bath.

4.1.5. Set Point

The “Set Point” button opens a screen for quick manual setting of the bath temperature.

4.1.6. Log Data

The “Log Data” button will begin to store the bath temperature data to a standard comma separated values format file. This file is stored in “C:\Results\YYYY\YYYY-MM\FluidBath_DataLog_YYYYMMDD_0001.csv”. This path and name is generated automatically where “YYYY” is the year, “MM” is the month, and “DD” is the day. To keep file sizes reasonable and to ensure there are no filename conflicts the name is also given a 4 digit incremental number as well. The “Log Data” button will change to a “Stop Logging” button when there is an active logging operation.

4.1.7. Setup

The “Setup” button opens the screens used to configure the system and calibration parameters of the 5600 Fluid Bath. Note that the calibration parameters are password protected.

4.2. SET POINT SCREEN

The Set Point Screen is a simple screen for changing the temperature value of the 5600 bath fluid. You can enter any value from 0 to 55 degrees Celsius, which is the operating range of the bath. Note that for values of zero and below it is recommended to use Glycol or a mixture of Water and Glycol to ensure the fluid does not freeze. To use this screen simply type in the desired Set Point value and press “OK” to accept. Click on “Cancel” to close the Set Point window without changing the value.

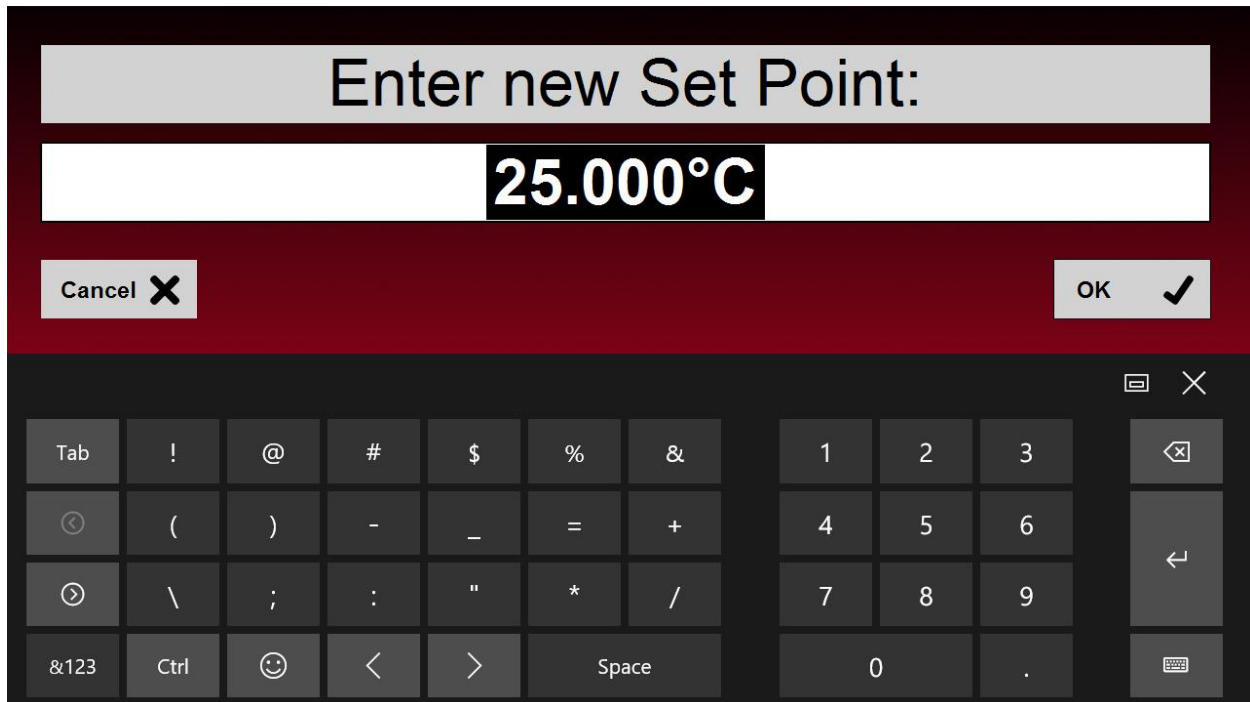

The Set Point Screen can easily be accessed directly on the Main Screen by touching the “SET POINT” button on the right hand side of the screen.

4.2.1. Cancel

The “Cancel” button will close the Set Point screen without applying any changes.

4.2.2. OK

The “OK” button will implement the new Set Point as displayed on the screen.

4.3. RUN PATTERN SCREEN

The Run Pattern screen allows for you to have the fluid bath run a pattern of various set points for temperature profiling the contents of the fluid bath. The Set Point will be automatically changed after a chosen time interval. The Set Points can be added and removed from the pattern using the “+” and “-” icons beside the table to the upper right. The pattern entries can also be directly edited by selecting them in the table.

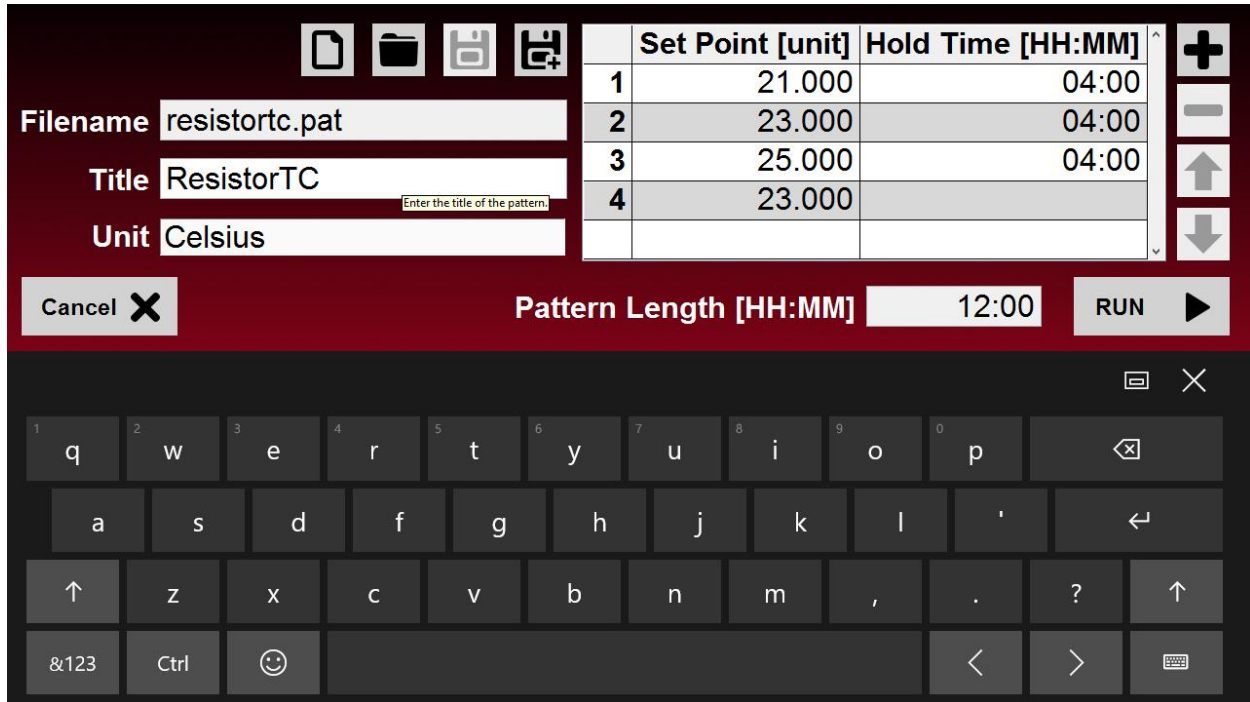

The patterns can be stored and recalled using the icon to the left of the screen. These icons represent “New File”, “Open File”, “Save File”, and “Save File As” in order from left to right.

4.3.1. Filename

The “Filename” field is where you can see the name for the file in which the pattern on the screen is saved. This field cannot be edited; it is an indicator of the active file once the file has been saved or loaded. Pattern files are saved with “*.pat” extension.

4.3.2. Title

The “Title” field is where you can edit and view the title of the test pattern. This is intended to provide an easy way for you to recall the purpose of the test pattern.

4.3.3. Unit

The “Unit” field is drop menu listing all of the available units in which the pattern is used in. You can select “Celsius”, “Fahrenheit”, “Kelvin”, or “Ohms”.

4.3.4. Pattern Length [HH:MM]

The “Pattern Length [HH:MM]” field is a calculated field expressing the total time duration of the active pattern sequence.

4.3.5. Cancel

The “Cancel” button will close the “Run Pattern” screen and not execute the pattern.

4.3.6. Run

The “Run” button will execute the pattern as displayed on the screen.

4.4. SETUP GUI SCREEN

The Setup GUI screen sets the basic graphing parameters for the main screen. Provided on the right of the screen are buttons to navigate to the other Setup screens. To the left are tabs to switch from the Setup screens to the Cal screens. Note the Cal screens are password protected.

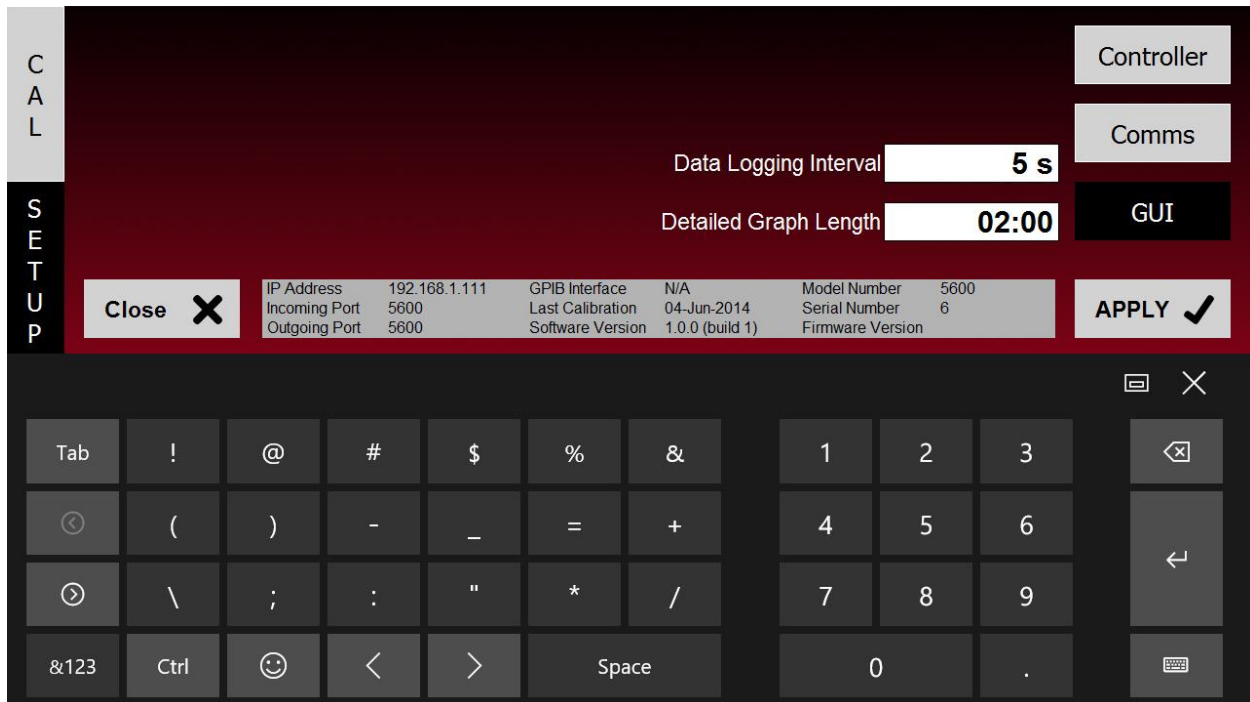

4.4.1. Data Logging Interval

The “Data Logging Interval” field is where the operator can set the rate in which the fluid bath updates the graph and statistics.

4.4.2. Detailed Graph Length

The “Detailed Graph Length” field is where the operator can set the length in time that graph will display and for which statistics are calculated.

4.4.3. Close

The “Close” button will close the Setup screen.

4.4.4. Apply

The “Apply” button will implement the parameters as displayed on the screen.

4.5. SETUP CONTROLLER SCREEN

The Setup Controller screen sets the Temperature reporting parameters for the Auxiliary Monitor Probe (i.e. Probe typically measuring the actual temperature inside the bath chamber). Provided on the right of the screen are buttons to navigate to the other Setup screens. To the left are tabs to switch from the Setup screens to the Cal screens. Note the Cal screens are password protected.

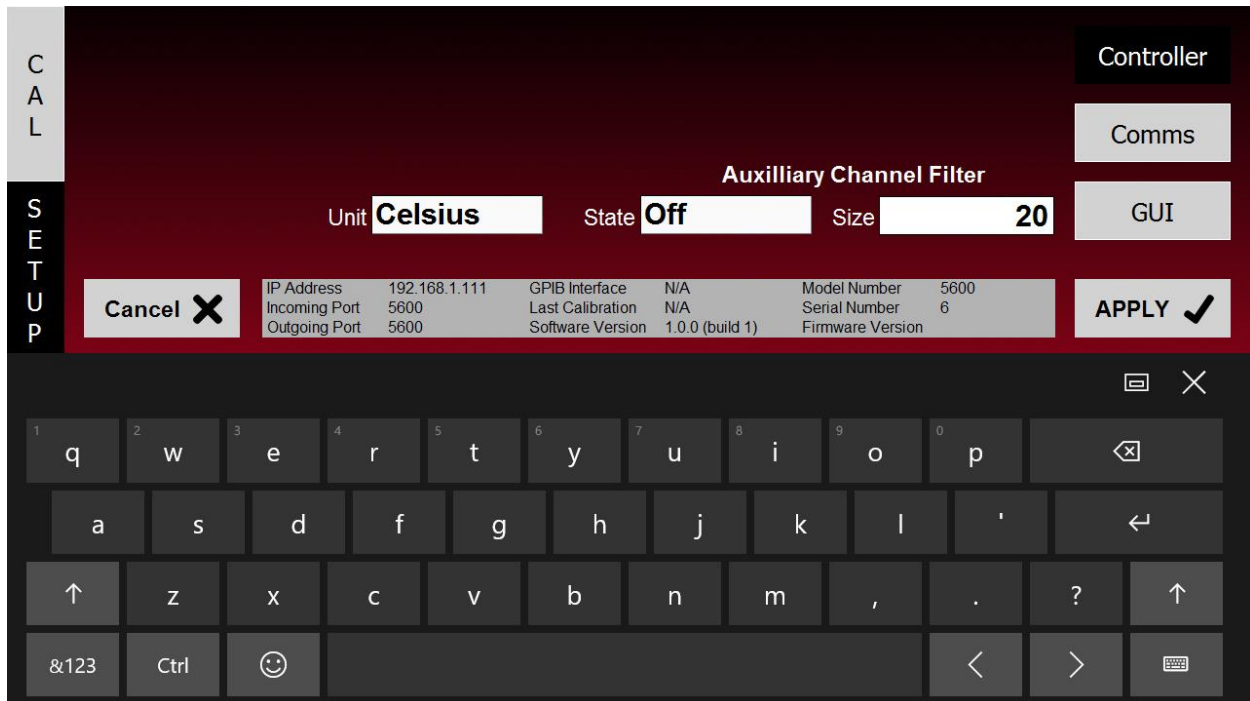

4.5.1. Unit

The “Unit” field is drop menu listing all of the available units in which the pattern is used in. You can select “Celsius”, “Fahrenheit”, “Kelvin”, or “Ohm”.

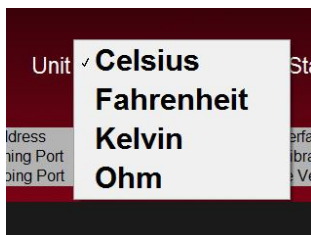

4.5.2. State

The “State” field is where the operator can enable or disable the filter on the Auxiliary Monitor Probe. The filter is essentially a backward average of the most recent number of measurements (i.e. Size).

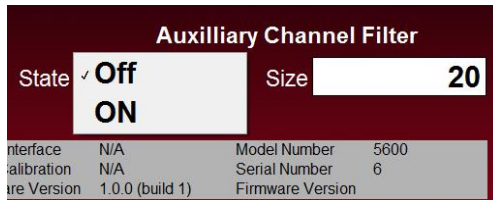

4.5.3. Size

The “Size” field is where the operator can set the size of the Auxiliary Monitor Probe filter by number of samples.

4.5.4. Cancel

The “Cancel” button will close the Setup screen without applying any changes.

4.5.5. Apply

The “Apply” button will implement the parameters as displayed on the screen.

4.6. SETUP COMMS SCREEN

The Setup Comms screen sets the Remote and Internal Communication parameters. Provided on the right of the screen are buttons to navigate to the other Setup screens. To the left are tabs to switch from the Setup screens to the Cal screens. Note the Cal screens are password protected.

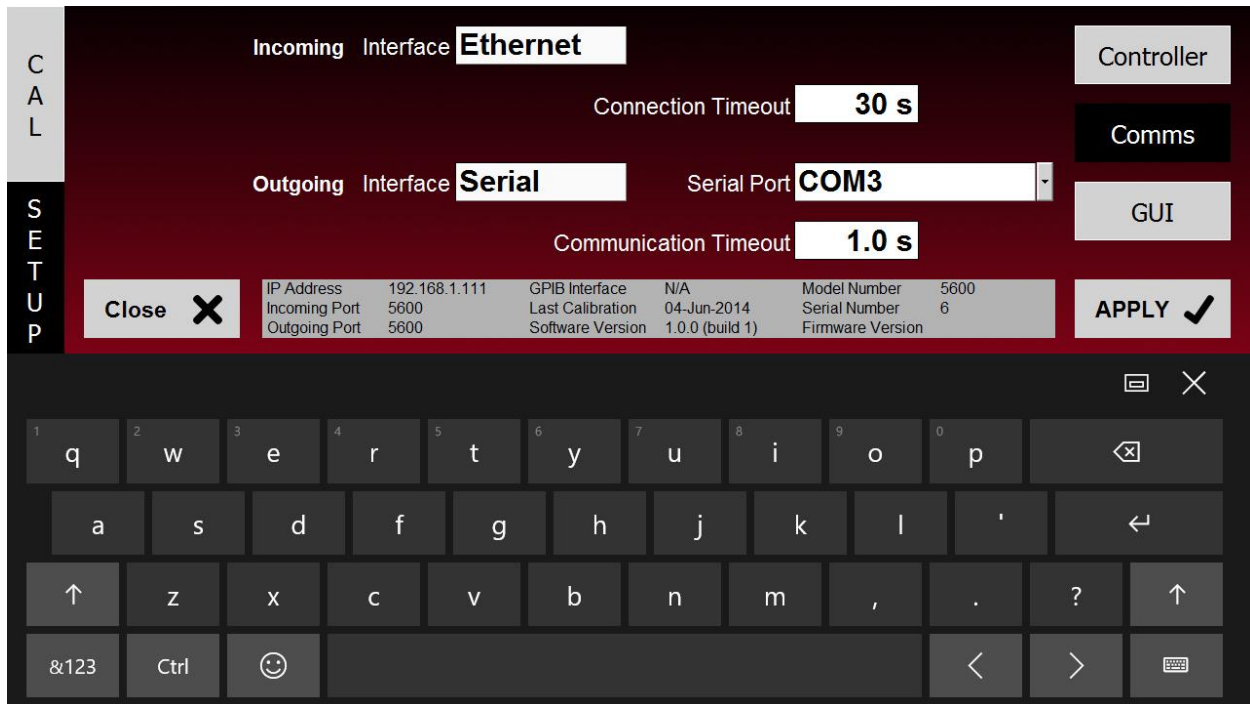

4.6.1. Incoming Interface

The “Incoming Interface” field is drop menu listing all of the available interfaces for connecting the 5600 Fluid Bath to an external computer for remote control. More detail on how to remotely control the 5600 Fluid Bath is outlined in the Remote Control Section of this manual. You can select the desired interface option based on the installed available option. These can be GPIB, Ethernet or Network Serial.

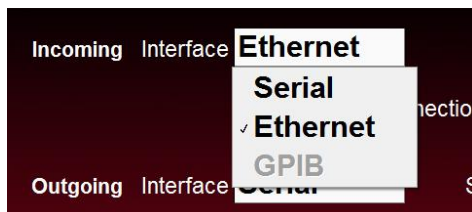

4.6.2. Connection Timeout

The “Connection Timeout” field allows the operator to set the time the GUI will wait for a connection from a remote PC before closing the active connection.

4.6.3. Outgoing Interface

The “Outgoing Interface” field is drop menu listing all of the available interfaces for connecting the 5600 Fluid Bath to an external computer for remote control. More detail on how to remotely control the 5600 Fluid Bath is outlined in the Remote Control Section of this manual. You can select the desired interface option based on the installed available option. These can be GPIB, Ethernet or Network Serial. There is also a “Simulation option which emulates a connection to the 5600 Fluid Bath hardware.

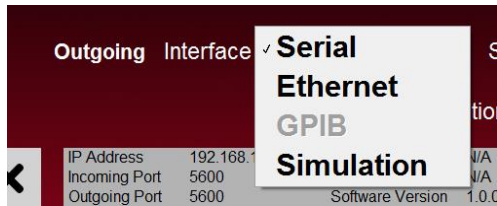

4.6.4. Serial Port/GPIB Address/ IP Address

The “Serial Port” field (i.e. sometimes called “GPIB Address” or “IP Address”) is a drop menu listing all of the available ports/addresses for connecting to the 5600 Fluid Bath hardware. Note that one of these fields will also appear next to the “Incoming Interface” depending on what interface is chosen.

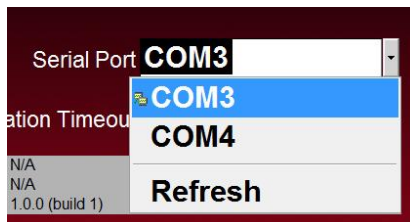

4.6.5. Communication Timeout

The “Communication Timeout” field allows the operator to set the time the GUI will wait for a response from the 5600 Fluid Bath hardware before reporting a connection error.

4.6.6. Close

The “Close” button will close the Setup screen without applying any changes.

4.6.7. Apply

The “Apply” button will implement the parameters as displayed on the screen.

4.7. PASSWORD SCREEN

The Password screen will appear whenever an operator attempts to enter the “Cal” screens. This is a precautionary measure to ensure that the parameters that affect the calibration and temperature control are not inadvertently changed.

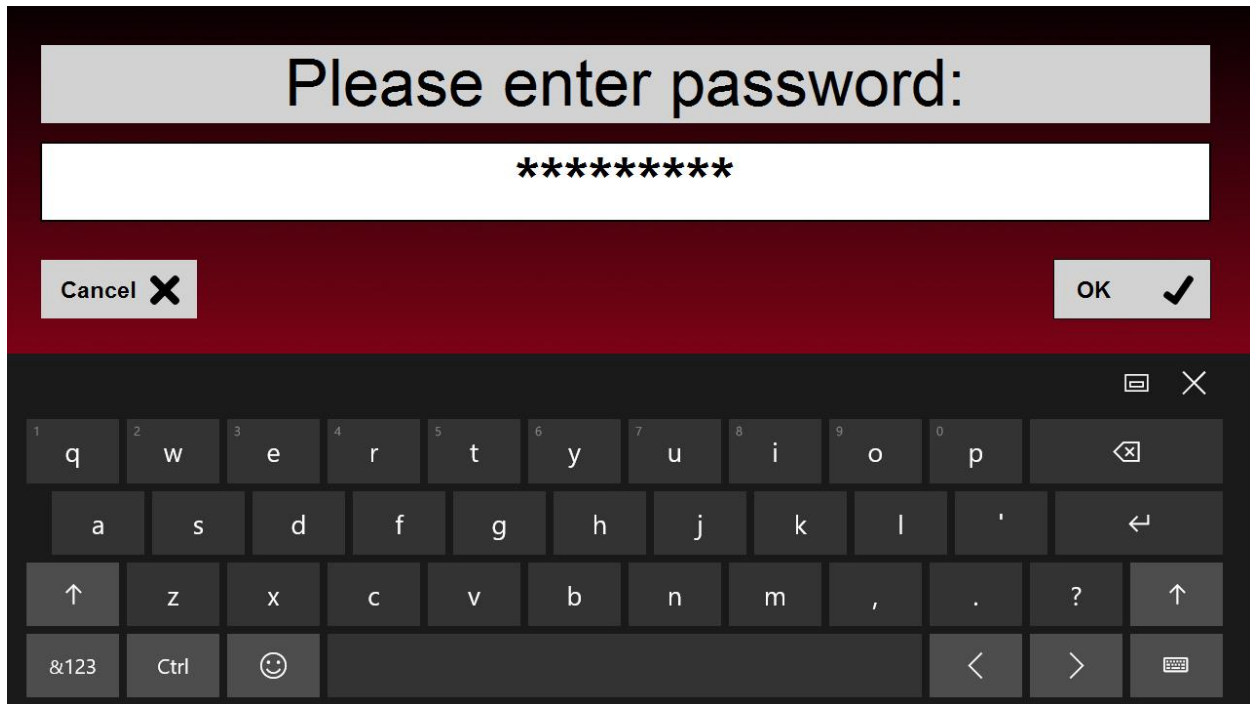

The password by default is “Guildline” and can be reset or changed by modifying the stored password in the “FluidBath5600.ini” file stored in the program directory under the key “Password”.

Note that to edit this file you will need administrative privileges in Windows.

4.7.1. Cancel

The “Cancel” button will close the Password screen denying access to the “Cal” screens.

4.7.2. OK

The “OK” button will submit the password and close the Password screen. If the password entered is correct, then access will be granted and you will be at the “Cal” screen(s).

4.8. SETUP CONTROLLER SCREEN

The “Setup Controller” screen allows the setting of the parameters used to control the bath temperature and stability. These parameters do not affect the calibration accuracy, but do affect the 5600 Fluid Bath’s ability to reach and maintain temperature.

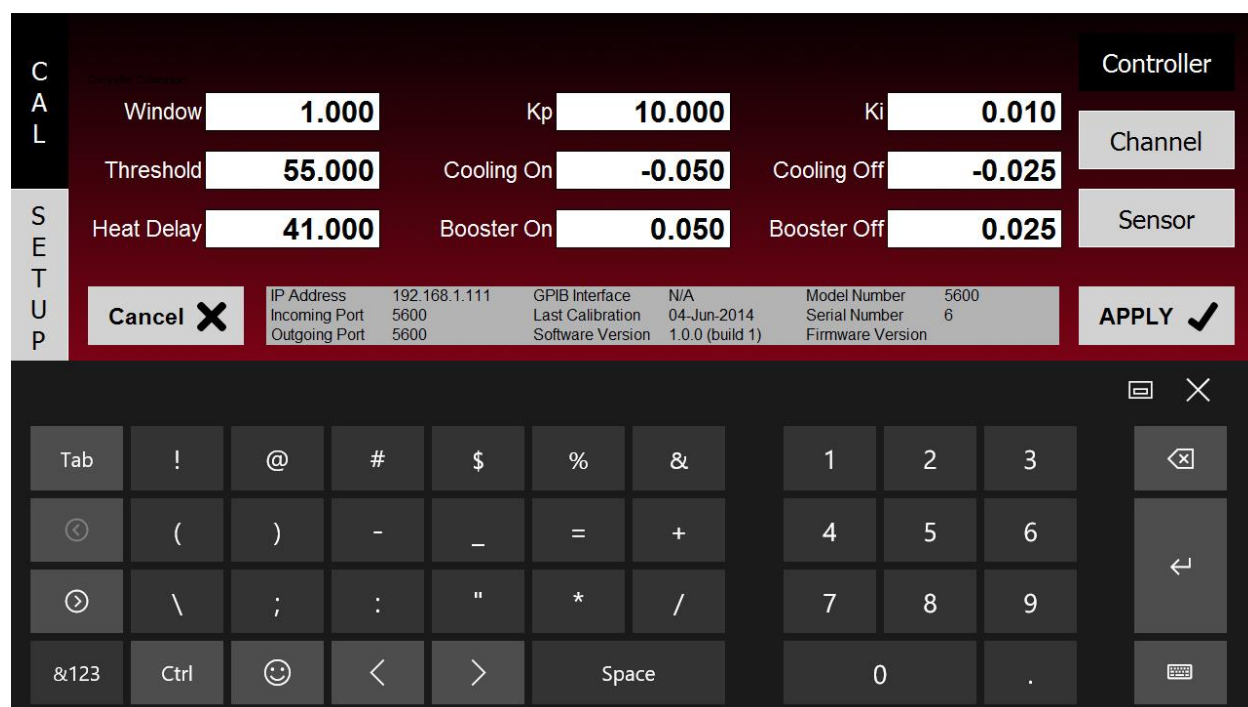

The bath maintains temperature based on the PID algorithm inside the temperature controller within the bath. The settings on this screen allow the operator to adjust and optimize the bath temperature control to their environmental conditions and operational requirements.

Note: The temperature error described in the following parameters is Set Point temperature minus actual temperature.

4.8.1. Window

The “Window” field allows setting of the Window value (any value in the range 0.00 through 1.00). Window is the temperature either side of the set point temperature, within which only the “integral” PID servo control is employed.

4.8.2. Kp

The “Kp” field allows setting of the Kp value (any value in the range 0.00 through 100.00). This is the “proportional” parameter of the PID control.

4.8.3. Ki

The “Ki” field allows setting of the Ki value (any value in the range 0.00 through 0.10) This is the “integral” parameter of the PID control.

4.8.4. Threshold

The “Threshold” field allows setting of the Threshold value (any value in the range 0.00 through 55.00 °C). The Threshold sets the temperature above which the cooling module should no longer be used.

4.8.5. Cooling On

The “Cooling On” field allows setting of the Cool On value (any value in the range 0.00 through 35.00 °C). The Cooling On sets the temperature error threshold, above which the cooling module is turned on.

4.8.6. Cooling Off

The “Cooling Off” field allows setting of the Cool Off value (any value in the range 0.05 through 35.00 °C). The Cooling Off sets the temperature error threshold, below which the cooling module is turned off.

4.8.7. Heat Delay

The “Heat Delay” field allows setting of the Heat Delay value (any value in the range 0.00 through 50.00 seconds). The Heat Delay sets how long after the cooling module has been turned off that the Booster Heater may be turned on.

4.8.8. Booster On

The “Booster On” field allows setting of the Booster On value (any value in the range 0.25 through 35.00 °C). The Boost On sets the temperature error threshold, below which the booster heater is used to speed up reaching the set point.

4.8.9. Booster Off

The “Booster Off” field allows setting of the Booster Off value (any value in the range 0.20 through 35.00 °C). The Booster Off sets the temperature error threshold, above which the booster heater is turned off while approaching the set point.

4.8.10. Close

The “Close” button will close the Cal screen without applying any changes.

4.8.11. Apply

The “Apply” button will implement the parameters as displayed on the screen.

4.9. CAL SENSOR SCREEN

The “Cal Sensor” screen defines the resistance to temperature details for both the Auxiliary and Control Temperature Probes. These sensors convert the measured property of Ohm to a temperature using the Callendar Van Dusen scale. The coefficients for this conversion for both the control channel and the Auxiliary monitoring channel are entered in this screen through the standard “A”, “B”, and “C” coefficients.

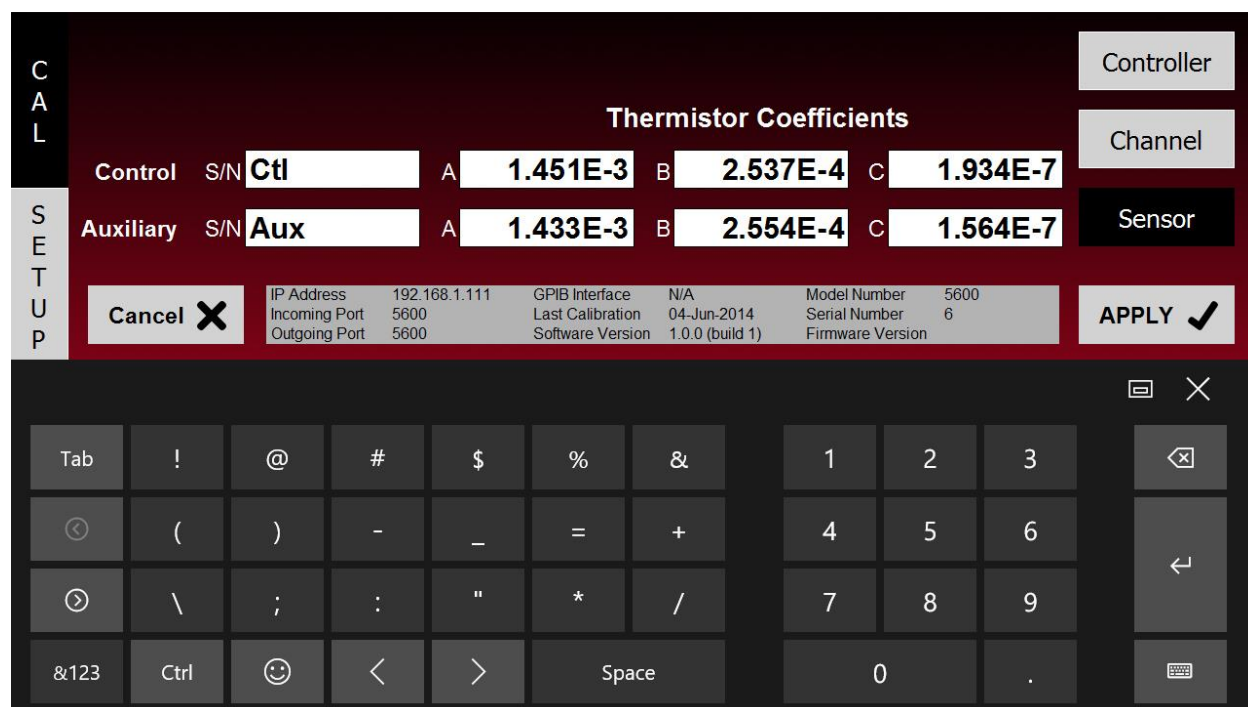

The screenshot shows the 'CAL SENSOR' screen with the following data:

		Thermistor Coefficients						Controller		
CAL SETUP	Control	S/N	Ctl	A	1.451E-3	B	2.537E-4	C	1.934E-7	Channel
	Auxiliary	S/N	Aux	A	1.433E-3	B	2.554E-4	C	1.564E-7	Sensor
Cancel X		IP Address	192.168.1.111	GPIB Interface	N/A	Model Number	5600			
		Incoming Port	5600	Last Calibration	04-Jun-2014	Serial Number	6			
		Outgoing Port	5600	Software Version	1.0.0 (build 1)	Firmware Version		APPLY ✓		

Below the data entry fields is a numeric keypad with the following layout:

Tab	!	@	#	\$	%	&	1	2	3	⌫
⏪	()	-	_	=	+	4	5	6	⏩
⏴	\	;	:	"	*	/	7	8	9	↶
&123	Ctrl	😊	<	>	Space		0	.		⌨

The Callendar Van Dusen scale is calculated by the following formula to convert the resistance reading of the sensor to temperature units. The formula utilizes 3 coefficients, which are unique to each sensor to derive and solve for temperature based on the sensor’s temperature dependence. These values are determined through calibration of the sensor and are implemented in the 5600 Fluid Bath through entry in this screen.

$$T = \left[A + B \ln(R_t) + C(\ln(R_t))^3 \right]^{-1}$$

4.9.1. Control and Auxiliary S/N

The “S/N” fields for both the Control and Auxiliary channels are where the operator can enter the serial numbers for each temperature sensor used in the 5600 Fluid Bath.

4.9.2. A, B, and C Thermistor Coefficients

The “Thermistor Coefficients” fields are labeled “A”, “B”, and “C” respectively representing the temperature to resistance conversion as per the standard Callendar Van Dusen scale. These fields allow the operator to enter the calibrated values for these coefficients. Caution that modifying these fields will affect the calibration of the bath. Great care should be exercised when modifying these values.

4.9.3. Close

The “Close” button will close the Cal screen without applying any changes.

4.9.4. Apply

The “Apply” button will implement the parameters as displayed on the screen.

4.10. CAL CHANNEL SCREEN

The “Cal Channel” screen allows the setting of the corrections for the linearity of the resistance measurement of the temperature sensors. The coefficients for this conversion for both the control channel and the Auxiliary monitoring channel are entered in this screen through the “C0”, “C1”, and “C2” linearization coefficients.

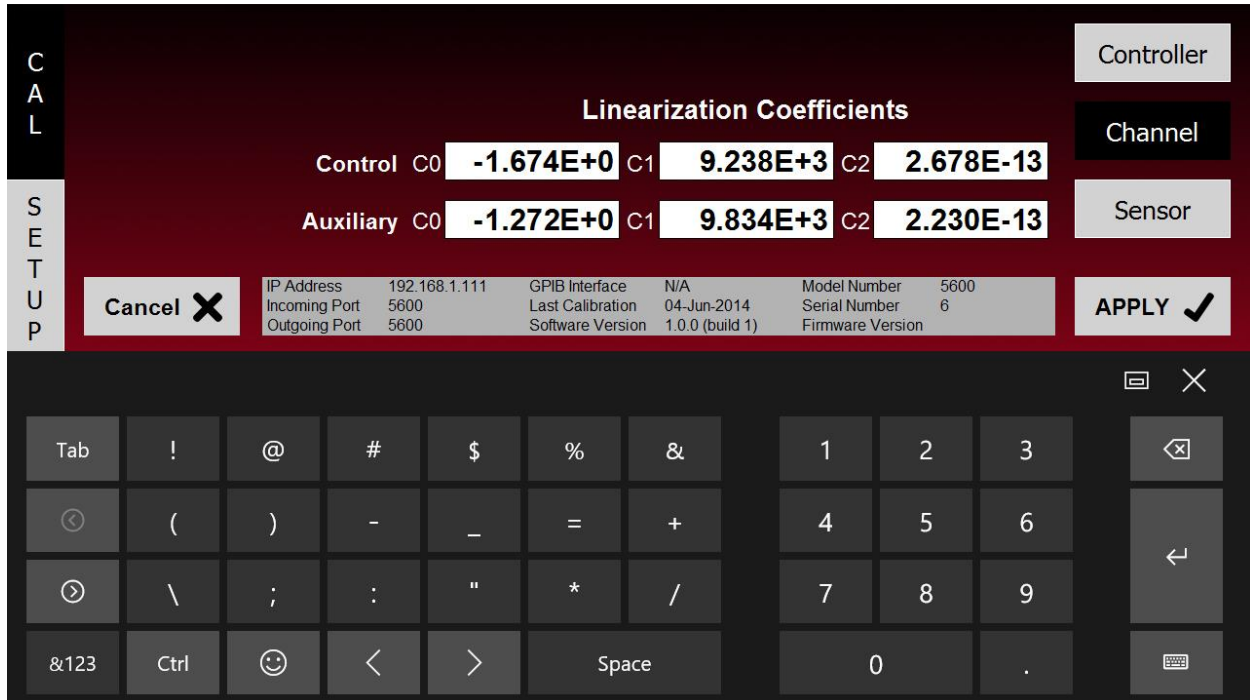

The screenshot shows the "CAL CHANNEL SCREEN" interface. On the left, a vertical menu contains "CAL" and "SETUP". The main area is titled "Linearization Coefficients" and is divided into two sections: "Control" and "Auxiliary".

Channel	C0	C1	C2
Control	-1.674E+0	9.238E+3	2.678E-13
Auxiliary	-1.272E+0	9.834E+3	2.230E-13

Below the coefficients, there is a "Cancel" button with an 'X' icon and an "APPLY" button with a checkmark icon. A status bar displays system information:

IP Address	192.168.1.111	GPIO Interface	N/A	Model Number	5600
Incoming Port	5600	Last Calibration	04-Jun-2014	Serial Number	6
Outgoing Port	5600	Software Version	1.0.0 (build 1)	Firmware Version	

At the bottom of the screen is a numeric keypad with various function keys like Tab, !, @, #, \$, %, &, 1-9, 0, ., and a keyboard icon.

The resistance measurement accuracy of each channel is factory adjusted and calibrated by Guildline. The coefficients represent corrections at specific resistance values across the dynamic range of the sensors used. The sensors used are 2.252k Ohm thermistors which have an operation range of approximately 600 Ohms to 10k Ohms. These corrections are used by the fluid bath to maintain a linear resistance reading across this range.

4.10.1. C0, C1, and C2 Linearization Coefficients

The “Linearization Coefficients” fields are labeled “C0”, “C1”, and “C2” respectively, representing the non-linearity adjustments for each of the Fluid Bath’s resistance channels. These fields allow the operator to enter the calibrated values for these coefficients. Caution that modifying these fields will affect the calibration of the bath. Great care should be exercised when modifying these values.

4.10.2. Close

The “Close” button will close the Cal screen without applying any changes.

4.10.3. Apply

The “Apply” button will implement the parameters as displayed on the screen.

5. REMOTE CONTROL

The 5600 Fluid Bath operates directly from the user interface or under remote control of an external instrument controller, computer or terminal. Remote control can be interactive, with the user controlling each step from a terminal, or under the control of a computer running the 5600 in an automated system.

This chapter describes the interfaces and the commands to which the 5600 will respond.

5.1. INTERFACES

The model 5600 has three interfacing standards available through the use of the remote pass through on the laptop computer:

A parallel interface conforming to IEEE-488.2.

A serial interface conforming to RS-232C.

A network interface conforming to TCP/IP.

The IEEE-488 is implemented through connecting a USB/GPIB adapter to the laptop computer.

The RS-232C is implemented through connecting a USB/RS-232C adapter to the laptop computer.

The TCP/IP is implemented through connection to the wireless adapter to the laptop computer or by an external USB to network adapter connected to the computer.

The 5600 can be only operated via one of the interfaces at a time.

5.2. IEEE-488 (GPIB) INTERFACE

The 5600 is fully programmable for use on the IEEE standard 488.1 interface bus (also known as the General Purpose Interface Bus (GPIB)). The interface is also designed in compliance with the supplemental standard IEEE-488.2. Devices connected to the bus in a system are designated as talkers, listeners, talker/listeners, or controllers. The 5600 can be operated on the IEEE-488 bus as a talker or under the control of an instrument controller as a talker/listener.

This manual assumes that the user is familiar with the basics of the IEEE-488 interface bus.

The IEEE-488 interfacing standard applies to the interface of instrumentation systems or portions of them, in which the:

1. Data exchanged among the interconnected apparatus is digital.
2. Number of devices that may be interconnected by one contiguous bus does not exceed 15.

3. The total transmission path lengths over the interconnecting cables does not exceed the lesser of either 20 meters or 2 meters times the number of devices on the bus.
4. Data rate across the interface on any signal line does not exceed 1 megabit per second.

5.2.1. CONTROLLER

There can be only one designated controller in charge on the IEEE-488 bus. This device exercises overall bus control and is capable of both receiving and sending data. The rest of the devices can be designated as listener, talker or talker/listener.

The controller can address other devices and command them to listen, address one device to talk and wait till the data is sent. Data routes are set by the controller but it need not take part in the data interchange.

All controller query and command sequences should be terminated with the line-feed character (0x0A) and/or optionally, the controller should assert the EOI data byte control signal.

5.2.2. IEEE-488 RESPONSES

The reply to any IEEE-488 query command will be a sequence of ASCII characters followed by a line-feed character (0x0A). The line-feed character may also be expressed as 0A₁₆ or 10₁₀ or 12₈ or Ctrl-J. Throughout this manual we will use the "C" programming language notation for expressing numbers in base 16, specifically 0x0A indicates that 0A is to be interpreted in base 16 (hex).

5.2.3. INTERCONNECTING CABLE AND IEEE-488 CONNECTOR

The interconnecting cable of IEEE-488 1978 consists of 24 conductors, 16 conductors are for carrying signals and 8 for grounding. An individual cable assembly may be up to 4 meters long and should have both a plug and a receptacle connector type at each end of the cable. Each connector assembly is fitted with a pair of captive locking screws.

5.2.4. TYPICAL SYSTEM

Data Input/Output Lines - The 8 data I/O lines form the data bus over which data between the various devices is transmitted under the supervision of the controller. The message bytes are carried on Data I/O signal lines in a bit parallel byte serial form, asynchronously and generally in a bi-directional manner.

Handshake or Data Byte Control - The three interface signals are used to effect the transfer of each byte of data on the DIO signal lines from a talker or controller or one or more listeners.

1. DAV (DATA VALID) is used to indicate the condition of (availability and validity) information on the DIO signal lines.
2. NDAC (NOT DATA ACCEPTED)

3. NRFD (NOT READY FOR DATA) is used to indicate the condition of readiness of devices to accept data.
4. SRQ (SERVICE REQUEST) is used by a device to indicate the need for attention and to request an interruption of the current sequence of events.
5. REN (REMOTE ENABLE) is used (by a controller) in conjunction with other messages to select between two alternate sources of device programming data.
6. EOI (END OR IDENTIFY) is used (by a talker) to indicate the end of a multiple byte transfer sequence or in conjunction with ATN (by a controller) to execute a polling sequence.
7. ATN (ATTENTION)
8. IFC (INTERFACE CLEAR)

5.2.5. ADDRESS AND TALK/LISTEN SELECTION

The IEEE-488 Address and Talk/Listen status can be set using the front panel controls as directed by the operator menuing system.

If there is no controller and the 5600 is hooked up to a printer for hard copy then Talk Only mode should be selected as the preferred mode of operation.

5.2.6. IEEE-488 ELECTRICAL INTERFACE

The 5600 meets the subsets of the IEEE-488 interface specification IEEE-488.1 shown in Table 5-1. The pin connections on the IEEE-488 interface connector are shown in Table 5-2.

Source Handshake	SH1	complete source handshake capabilities.
Acceptor Handshake	AH1	complete acceptor handshake capabilities.
Talker	T5	has a talker capability with a single primary address in the range 0 to 30. Extended addressing is not implemented. Talk only.
Listener	L4	supports basic listener with unaddressed if MTA(My Talk Address) is received. The talk and listen addresses will always be the same. Does not support extended listen addresses. Does not support Listen Only.
Service Request	SR1	complete service request generation capabilities.
Remote Local	RL1	all functions on the front panel can be locked out by the IEEE-488 controller.
Parallel Poll	PP0	no parallel poll capabilities.
Device Clear	DC1	full device clear capabilities.
Device Trigger	DT0	no device trigger capabilities.
Controller	C0	can never become the bus controller.
Electrical Interface	E2	all required electrical interface capability.

Table 5-1 : IEEE-488 Device Capabilities

PIN	NAME	DESCRIPTION
1	DIO1	Data Input Output Line 1
2	DIO2	Data Input Output Line 2
3	DIO3	Data Input Output Line 3
4	DIO4	Data Input Output Line 4
5	EIO	End or Identify
6	DAV	Data Valid
7	NRFD	Not Ready for Data
8	NDAC	Not Data Accepted
9	IFC	Interface Clear
10	SRQ	Service Request
11	ATN	Attention
12	SHIELD	Screening on Cable (connected to safety ground)
13	DIO5	Data Input Output Line 5
14	DI06	Data Input Output Line 6
15	DIO7	Data Input Output Line 7
16	DIO8	Data Input Output Line 8
17	REN	Remote Enable
18	GND6	Ground wire of twisted pair with DAV
19	GND7	Ground wire of twisted pair with NRFD
20	GND8	Ground wire of twisted pair with NDAC
21	GND9	Ground wire of twisted pair with IFC
22	GND10	Ground wire of twisted pair with SRQ
23	GND11	Ground wire of twisted pair with ATN
24	GND	Logic Ground

Table 5-2 : IEEE-488 Pin Designations

5.2.7. IEEE-488 INPUT BUFFERING

The IEEE-488 input buffer is 256 bytes long. The input full bit is set when the buffer is above 75 % full (64 bytes remaining), hence if the programmer limits messages sent to the 5600 to 32 bytes and checks the IFL bit in the status register before sending each message, then under normal operating conditions the buffer should never overflow. If the buffer is full and the programmer sends more data, the 5600 will perform the necessary handshaking as per usual, but the data will be lost. This is done for two reasons:

If the buffer is full, the fault must have originated with the controller, since the 5600 interprets most commands in fewer than 15 milliseconds. This prevents the 5600 from locking up the IEEE-488 bus.

5.2.8. IEEE-488 OUTPUT BUFFERING

Output from query commands are placed into a 256 byte output buffer. When the controller reads data from the 5600 the responses will come from the output buffer in, first-in first-out order. If for some reason the controller does not read the responses from its query commands the output buffer will overflow, in this case the first data into the buffer will still be valid and the later data will be lost. When output data is lost the query error bit in the status register will be set. When the output buffer is not empty then the message available (MAV) bit will be set in the status register.

5.2.9. IEEE-488 DEADLOCK

If the controller demands a byte of data from the 5600 and the buffer is empty, the 5600 will set the Query Error flag in the Event Status Register.

5.3. RS-232C INTERFACE

The 5600 can optionally have an RS-232C interface which can be connected to a controller or to a simple printer. The controller (which can be almost any computer with an RS-232C interface) can control the 5600 through a variety of commands which allow setting the instruments operating parameters, and analyzing the measurements made by the 5600. The simple printer interface can be used to log any or all of the measurements taken by the 5600 during normal operation.

When using the RS-232C port to remotely control the 5600, either interactively with a terminal or under computer control, operation is the same as using an IEEE-488 controller connected to the IEEE-488 port for control, with the following exceptions:

1. The program message terminator is Carriage Return (0x0D).
2. There is no SRQ capability when using serial remote control. The status registers still behave as described in this chapter, but the 5600 serial interface does not have a way to perform the SRQ function.
3. There is no direct way to perform IEEE-488 hardware interface functions such as DCL (Device Clear) or SDC (Selected Device Clear).

Pin		Function	Direction
1	CHG	Chassis Ground	IN/OUT
2	TxD	Transmit Data	IN
3	RxD	Receive Data	OUT
4	RTS	Request To Send	IN
5	CTS	Clear To Send	OUT
6	DSR	Data Set Ready	OUT
7	GND	Signal Ground	IN/OUT
8	DCD	Data Carrier Detect	OUT
20	DTR	Data Terminal Ready	IN
All other pins not used or connected			

Table 5-3 : RS232 Pin Designations

The 5600 Variable Temperature Fluid Bath is a data communication equipment (DCE) so TxD is an input (the data which the modem is to transmit).

5.3.1. RS-232C RESPONSES

The reply to any RS-232C query command will be a sequence of ASCII characters followed by a Carriage-Return character (0x0D) and then a Line-Feed character (0x0A). The Line-Feed character may also be expressed as 0A₁₆ or 10₁₀ or 12₈ or Ctrl-J. Throughout this document we will use the "C" programming language notation for expressing numbers in base 16, specifically 0x0A indicates that 0A is to be interpreted in base 16 (hex).

5.4. COMMAND LANGUAGE

The commands for IEEE-488 and RS-232C mainly correspond to the labels assigned to the front panel menus. Throughout this document when examples are given they apply to commands through the RS-232C interface or through the IEEE-488 interface. The examples will not show the termination characters since these differ for each of the interfaces (See sections 5.2.2. and 5.3.1.).

5.4.1. GENERAL SYNTAX FOR COMMANDS

The 5600 uses a sophisticated command parser which can usually determine which command was desired, even if the command is entered incorrectly. Some care should be taken when sending commands such as `SYSTEM:VERBose` and `SYSTEM:VERSion?` Since the parser may not be able to decide which command was desired in the event of a gross misspelling (such as using `VERBion` instead of `VERSion`).

No command used in the 5600 has an embedded space in its name, spaces (0x20) are used only to separate command names from their parameters.

The comma "," must delimit all multiple arguments used in a command sequence.

Throughout this manual some of the command names will have an UPPER case portion and a lower case portion. The command may be shortened such that only the portion of the command name which was presented in UPPER case characters is present. The command parser of the 5600 is case insensitive (i.e. the letter case of commands sent to the 5600 does not matter), both UPPER case letters and lower case letters may be used.

5.4.2. GENERAL SYNTAX FOR NUMBERS

Numeric parameters may have up to 30 characters, and although the 5600 will accept numeric parameters in the range $\pm 2.2E-308$ through $\pm 1.8E308$, the useful range of numbers is between $\pm 1.0E-8$ and $\pm 1.0E5$.

The portion of the command parser which interprets numeric input will correctly recognize most common forms of numeric input, for example the following are all valid methods of expressing the number 123.4:

123.4
123.4e00
0.1234E3
1234e-1
0000123.4

The following are examples of invalid forms of expressing a number:

123.4 e00	space between mantissa and exponent letter
1234D-1	exponent not e or E
n123.4	letter in front of the first digit
e34	missing mantissa

Multipliers (such as μ , m, k, and M) are not permitted on commands, all numbers must be entered in the base units, for example 100 mV can be expressed as 100e-3 or 0.100. Expressions (for example 7 + 20 X 3) are not allowed as parameters.

5.5. REMOTE AND LOCAL OPERATION

The 5600 can be operated using the front panel keys or it can be operated remotely using a remote controller. In addition the 5600 can be placed in a local lockout condition at any time by a command from the controller. When combined, the local, remote, and lockout conditions yield four possible operating states:

5.5.1. LOCAL

The 5600 responds to local and remote commands. This is also called "Front Panel Operation". Only remote commands that do not affect the state of the 5600 are allowed to execute. For example the command FETCh? A is allowed to operate but the command MEASure:SENsOr A,1 which would change the instrument state (use sensor number 1 for the Ctl Channel input) is not allowed. If the controller sends a command which would affect the instrument state while in local, the command will be ignored, and an Execution Error indication will be given.

5.5.2. LOCAL WITH LOCKOUT

Local with lockout is identical to Local except that the 5600 will go into remote with lockout instead of the remote state when the 5600 receives a remote command. The local with lockout state is entered by sending an IEEE-488 LLO+REN command from the controller, or by sending the RS232 LOCKOUT command to the 5600.

5.5.3. REMOTE

When the Remote Enable (REN) line is asserted and the controller addresses the 5600 as a listener, the 5600 enters the remote state.

Front panel operation is restricted to the use of the <Escape> key. Pressing the <Escape> key or sending the GTL (Go To Local) interface message returns the 5600 to the local state.

5.5.4. REMOTE WITH LOCKOUT

The remote with lockout state can be entered from remote or local with lockout, but not directly from local. Remote with lockout is similar to the remote state but restricted: the <Escape> key will not return to the local state. To return the 5600 to the local with lockout state the controller must send a GTL interface command. To return the 5600 to the local state the controller must unassert the REN control line. Table 5-4 summarizes the possible Remote/Local state transitions.

From	To	IEEE-488 Interface Command	RS-232C Interface Command
Local	Remote	MLA + REN	REMOTE
	Local / Lockout	LLO + REN	LOCKOUT
Remote	Local	GTL	LOCAL
	Remote / Lockout	LLO + REN	LOCKOUT
Local / Lockout	Remote / Lockout	MLA + REN	REMOTE
Remote / Lockout	Local	Not (REN)	LOCAL
	Local / Lockout	GTL	None

Table 5-4 : Remote/Local State Transitions

5.6. PROGRAMMING COMMAND SUMMARY

A brief description of each of the possible remote RS232 and IEEE-488 commands and their syntax in BNF (Backus Naur Form) follows:

words inside angle brackets (i.e. <digit>) are defined items

:= means "is defined to be"

{ } means "or"

words inside square brackets (i.e. [+]) means optional

Required letters are shown in upper case but may be upper or lower case.

<d>	:= {0 1 2 3 4 5 6 7 8 9}	
<l>	:= {A B C ... Z a b c ... z}	
<s>	:= {<l> <l><s>}	
	:= {0 1}	
<u>	:= {<d> <d><u>}	
<n>	:= [{+ -}]<u>	
<f>	:= <n>[.<u>][E<n>]	
<?>	:= {<l> <d>}	
<*>	:= {<?> <?><*>}	(not to be confused with *)
<DD>	:= <u>	(limited to range 1...31)
<MM>	:= <u>	(limited to range 1...12)
<YYYY>	:= <u>	(limited to ranges 0...38, 70...99 and 1970...2038)
<hh>	:= <u>	(limited to range 0...23)
<mm>	:= <u>	(limited to range 0...59)
<ss>	:= <u>	(limited to range 0...59)

COMMAND	COMMENT
*CLS	clear event status register, empty input queue
*ESE <u>	set event status enable
*ESE?	report event status enable
*ESR?	report event status register
*IDN?	report identity of unit
*OPC	set operation complete bit in event status register
*OPC?	report operation complete
*OPT?	report any reportable options
*RST	reset the instrument to a known defined state
*SRE <u>	set the service request mask
*SRE?	report service request mask
*STB?	report serial poll status byte
*TST?	report results of self test
*WAI	wait for pending operations to complete
CONFigure:	
BOOSter?	report the Booster module status
COOLing?	report the Cooling module status
HEATer?	report the Heater power
WINDow <f>	set the Window variable for temperature control
WINDow?	report the Window variable for temperature control
SETPoint <f>	setup the Setpoint
SETPoint?	report the Setpoint
SETUp <f>,<f>,<f>,<f>,<f>,<f>,<f>,<f>	set the variables for the temperature control algorithm
SETUp?	report the variables for the temperature control algorithm
FETCh? {A B}	fetch most recent data value for the given channel
FETCh:	
DIFFerence?	fetch the most recent difference data value
HISTory?	fetch the history data
MEASure:	
CALCulation <u>	select difference calculation mode
CALCulation?	report difference calculation mode
FILTer ,<u>,<u>	set the digital filter state, type and size
FILTer?	report the filter setup
HISTory ,<u>,	set measurement history state, rate and mode
HISTory?	report measurement history configuration
HISTory:	
CLEAr	clear measurement history buffer
SENSor {A B},<u>	assign a thermistor (0...15) to the given input channel
SENSor? {A B}	report the thermistor assigned to the given input channel
TREND {A B}	reset trend data for given channel
TREND? {A B}	report trend data for given channel
UNIT {O C F K}	select the units of measurement
UNIT?	report the units of measurement

COMMAND	COMMENT
SOFCAL: CHANnel {A B},<u>,<f>,<f>,<f> CHANnel? {A B},<u> DATE <YYYY>,<MM>,<DD> DATE? SENSor <u>,... SENSor? <u> SYSTem: COMMunicate: GPIB <u>,<u> GPIB? SERial <u>,<u>,<u>,<u>,,<u> SERial? DATE <YYYY>,<MM>,<DD> DATE? DIAGnostic: ROMChecksum? SerialNUMBER <u> SerialNUMBER? TEST? <u> KEY? LOCAL LOCKOUT REMOte TERSe TIME <hh>,<mm>,<ss> TIME? VERBose VERSion?	set linearization coefficients for given channel and range report linearization coefficients for given channel and range set date of calibration report date of calibration program parameters for given thermistor report given thermistor parameters setup GPIB communications to given address and mode report GPIB set up setup RS232 communications to given baud rate, data bits, parity, stop bits, flow control, echo, and mode report RS232 set up enter the current calendar date report the current calendar date report ROM checksum assign serial number report unit serial number perform internal test of given type and report result report last key pressed enter the local state (RS232 only) enter the local lockout state (RS232 only) enter the remote state (RS232 only) respond to commands with a minimum data set enter the current time of day report the current time of day respond to commands with maximum data set report the installed software version

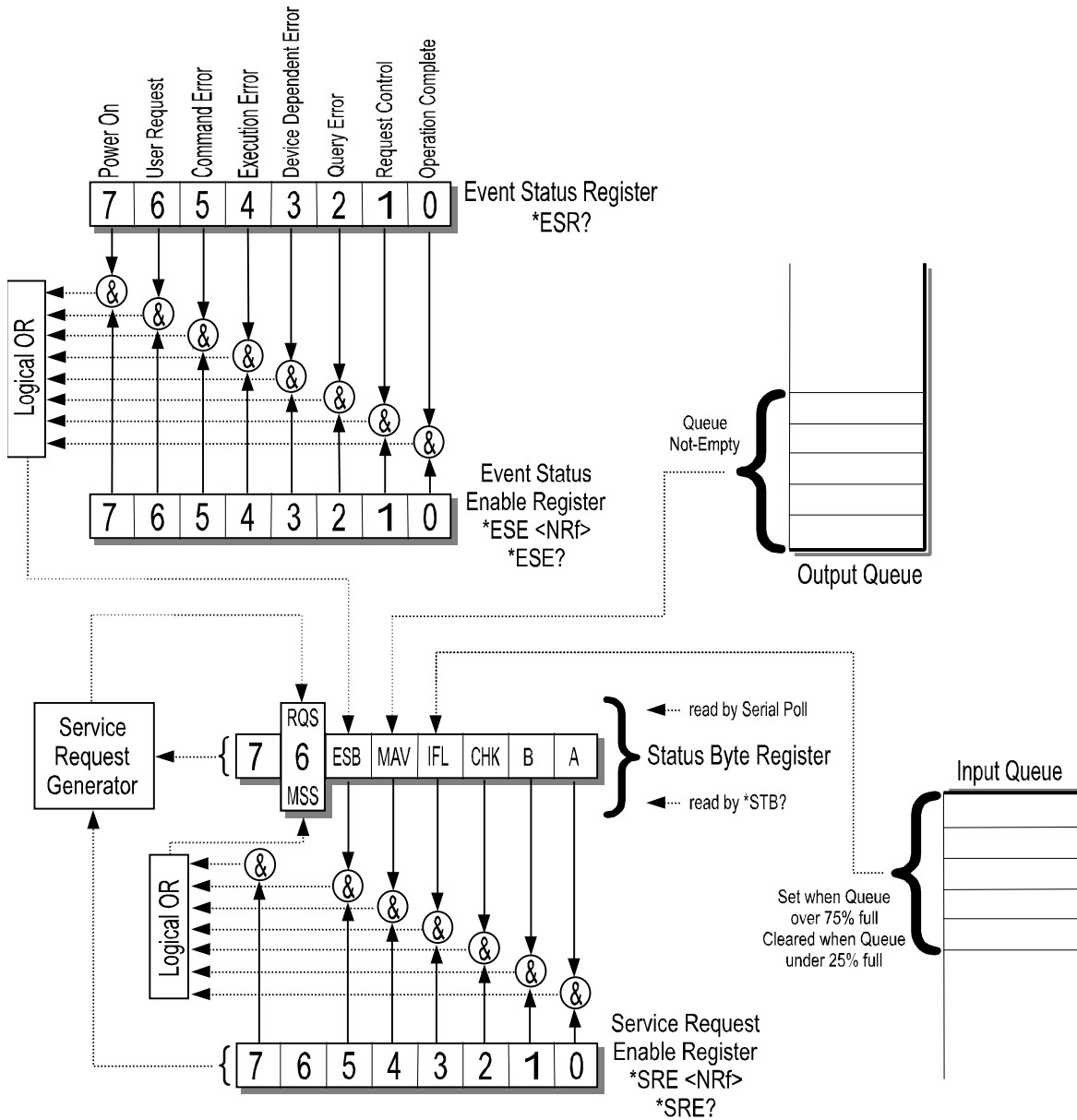

Figure 5-1 : Event Status Bit Operation

5.7. REMOTE COMMANDS

This section details all the valid commands which may be sent over either the IEEE-488 or the RS-232C interface port. The responses listed below are the verbose response.

If the numeric parameter to the command is missing or unrecognizable the CME (CoMmand Error) bit in the Event Status Register (see Figure 5-5) will be set. If the unrecognizable command was sent over the RS-232C interface, the 5600 will respond with “Unrecognized Command”.

If the numeric value is out of range then the EXE (EXecution Error) bit will be set for a program data element out of range error. If the out of range value was sent over the RS-232C interface, the 5600 will respond with “Invalid Parameter”.

Unless otherwise indicated, the terse response is that portion of the response printed in bold.

5.7.1. ***CLS - CLEAR STATUS COMMAND**

This command clears all Event Status Registers summarized in the status byte register. All queues, except the Output Queue, that are summarized in the status byte register are emptied. The 5600 is forced into the Operation Complete Idle State and the Operation Complete Query Idle state.

5.7.2. ***ESE <u> - SET EVENT STATUS ENABLE REGISTER**

This command sets the standard event status enable register bits. When the bits in the Event Status Enable (ESE) register are "ANDed" with the bits in the Event Status Register (ESR) if the result is non-zero then the Event Status Bit (ESB) in the Status Byte (STB) register is set.

The values accepted for the *ESE command are between 0 and 255, all other values are considered to be an error. The default value for the Event Status Enable (ESE) register at power on is zero (0).

5.7.3. ***ESE? - EVENT STATUS ENABLE QUERY**

This command reports the current value of the Event Status Enable Register. The value returned will be between 0 and 255.

5.7.4. ***ESR? - EVENT STATUS REGISTER QUERY**

This query allows the programmer to determine the current contents of the event status register. Reading the Event Status Register clears it.

Bit Location		Name	Description
0	LSB	OPC	OPERation Complete. This event bit is generated in response to the *OPC or *OPC? command. It indicates that the 5600 has completed any pending operations and that the parser is ready to accept more program messages.
1		RQC	ReQuest Control. This event bit indicates to the GPIB controller that the 5600 is requesting permission to become the controller in charge. The 5600 will never set this bit.
2		QYE	QuerY Error. This bit indicates that an attempt is being made to read data from the output queue when no output is either present or pending, or that data in the output queue has been lost (queue over-flow). See also GPIB Deadlock.
3		DDE	Device Dependent Error. Not Used.
4		EXE	EXExecution Error. Set when (1)a program data element is evaluated to be outside the legal input range or is inconsistent with the 5600's capabilities, (2)a valid program message could not be properly processed.
5		CME	CoMmand Error. Set when (1)a syntax error has been detected by the parser, (2)a semantic error has occurred indicating that an unrecognized header has been received, (3)A Group Execute Trigger was entered into the input buffer inside a program message.
6		URG	User Request. Set when any key is depressed on the 5600 keyboard.
7	MSB	PON	Power ON. This bit is set after the 5600 is powered up.

Table 5-5 : Event Status Register

5.7.5. *IDN? - IDENTIFICATION QUERY

This command causes the 5600 to reply with an identification string. The identification string is built up of four (4) fields delimited by commas (.). The first field is the manufacturer (i.e. Guildline Instruments), the second field is the model (i.e. 5600), the third field is the serial number (i.e. 55065), and the final field is the firmware revision (i.e. E). A typical response might read:

Guildline Instruments, 5600, 55065, E

5.7.6. *OPC - OPERATION COMPLETE

This command will cause the 5600 to set the Operation Complete bit (bit 0) in the Event Status Register. Since the 5600 processes all commands sequentially, the operation complete bit will be set as soon as the command is parsed.

5.7.7. *OPC? - OPERATION COMPLETE QUERY

This query will place a numeric 1 in the output buffer indicating that all pending operations are complete.

5.7.8. *OPT? - REPORT AVAILABLE OPTIONS

This query command reports the presence or absence of various options. The format of the reply is a series of arbitrary ASCII response fields separated by commas. The 5600 will always report the value 0.

5.7.9. *RST - DEVICE RESET

This command is intended to return the 5600 to a known state, specifically a return to terse mode. This command will not affect the following:

1. The output queue.
2. The state of the IEEE-488 interface.
3. The selected address of the 5600.
4. The *SRE setting.
5. The *ESE setting.
6. Calibration data that affects device specifications.

The *RST command will perform the following actions:

Clear the key-press buffer.

Make remote responses terse.

Set the measurement units to degrees Celsius.

Set the measurement display to the Aux Channel.

*RST is a MANDATORY IEEE-488.2 command.

5.7.10. *SRE <u> - SERVICE REQUEST ENABLE COMMAND

The service request enable command allows the 5600 to generate a service request on the IEEE-488 interface under a limited set of conditions. The limitations on the conditions are defined by the numeric parameter following the *SRE command. The numeric parameter is a decimal integer in the range 0-255. The numeric parameter when expressed in base 2 (binary) represents the bit values of the Service Request Enable Register. For all bits (except bit 6) a bit value of one (1) indicates an enabled condition and a bit value of zero (0) represents a disabled condition. *SRE? Is the companion query command.

5.7.11. *SRE? - SERVICE REQUEST ENABLE QUERY

This command allows a programmer to determine the current contents of the Service Request Enable Register. A decimal number between 0 and 63 or between 128 and 191 will be returned.

5.7.12. *STB? - STATUS BYTE QUERY

This command allows the programmer to read the status byte and master summary bits (shown in Table 5-6.).

The response from this command is a decimal integer in the range 0-255. This decimal integer when expressed in base 2 (binary) represents the bit values in the Status Byte Register. Note that the Master Summary Status bit and Not RSQ is reported in bit 6.

The Status Byte Register can also be read with the Read Serial Poll hardware command on the IEEE-488 interface.

This Register can be read by Serial Poll or by the *STB? command.

5.7.13. *TST? - QUERY RESULTS OF SELF TEST

This command is intended to report the status of any self-tests performed by the 5600. If the 5600 passes all of its self-tests then the reply will be 0.

The possible failure codes are the sum of :

- 1 Non-volatile memory failure
- 2 ROM checksum failure
- 4 Power supply failure.

5.7.14. *WAI - WAIT-TO- CONTINUE COMMAND

This command is intended to suspend the execution of any further commands until all pending operations have been completed. Since the 5600 does not implement a new command until the last operation has been completed, this command has no effect. It is included in the list of remote commands because it is a mandatory IEEE-488.2 command.

LOCATION	NAME	DESCRIPTION
0	LSB	A
		Set when the Ctl Channel measurement is completed. Cleared by the "FETCH? A" query.
1		B
		Set when the Aux Channel measurement is completed. Cleared by the "FETCH? B" query.
2		CHK
		CHecksum computation complete. This bit is set once, after instrument power on and the completion of the computation of the ROM checksum is cleared by the "SYST:DIAG:ROMC?" query .
3		IFL
		Input FuLl. This bit is set when the input queue is over 75% full and cleared when the queue drops below 25% full.
4		MAV
		Message AVailable. This bit is set when the output queue is not empty.
5		ESB
		Event Summary Bit. This bit is set when the result of a bitwise AND of the Event Status Enable register is not zero.
6		RQS
		ReQuest for Service. This bit is set when the result of a bit-wise AND of the Status Byte Register and the Service Request Enable register is not zero.
7	MSB	unused
		Always zero.

Table 5-6 : Status Byte Register

5.7.15. CONFigure: - SET OPERATING CONFIGURATION

This command allows a system programmer to configure the operating parameters for the instrument. The form of the configure command sequences are as follows:

- CONFigure: BOOSter?
display the booster heater status
- CONFigure: COOLing?
display the cooling module status
- CONFigure: HEATer?
display the heater power
- CONFigure: WINDow <window>
setup the control window (<window>:= <f>)
- CONFigure: WINDow?
display the control window setup
- CONFigure: SETPoint <setpoint>
setup the temperature setpoint (<setpoint>:= <f>)
- CONFigure: SETPoint?
display the temperature setpoint
- CONFigure: SETUp <thr>, <kp>, <ki>, <Coff>, <Con>, <delay>, <Bon>, <Boff>
set the temperature control operating parameters (<thr>:= <f>; <kp>:= <f>; <ki>:= <f>; <Coff>:= <f>; <Con>:= <f>; <delay>:= <f>; <Bon>:= <f>; <Boff>:= <f>)
- CONFigure: SETUp?
display temperature control operating parameters

5.7.15.1. CONFigure:BOOSter?

This query command requests the current booster heater status used for the temperature control. The response from the 5600 will be:

Booster Power **100.000** %

5.7.15.2. **CONFigure:COOLing?**

This query command requests the current cooling module status used for the temperature control. The response from the 5600 will be:

Cooling **1**

5.7.15.3. **CONFigure:HEATer?**

This query command requests the current heater power used for the temperature control. The response from the 5600 will be:

Heater Power **39.499 %**

5.7.15.4. **CONFigure:WINDow <window>**

The window command sets the window for the temperature control algorithm.

<window>:= <f> This parameter sets the Window variable for the temperature control algorithm. The valid range is from 0.000 to 1.000.

5.7.15.5. **CONFigure:WINDow?**

This query command requests the current window used for the temperature control. The response from the 5600 will be:

Window **0.006**

5.7.15.6. **CONFigure:SETPoint <setpoint>**

The setpoint command allows you to enter the desired temperature setpoint for the bath. The set point is entered in the currently displayed units.

<setpoint>:= <f> This parameter will allow setting of the temperature set point. The valid range is from 0.000 to 55.000.

5.7.15.7. **CONFigure:SETPoint?**

This query command requests the current setpoint used for the bath. The response from the 5600 will be:

Setpoint **23.000 C**

5.7.15.8. CONFigure:SETUp

`<thr>,<kp>,<ki>,<Coff>,<Con>,<delay>,<Bon>,<Boff >`

This command sets up the operating configuration for the temperature control algorithm of the 5600.

<code><thr>:= <f></code>	This parameter sets the Threshold variable for the temperature control algorithm. The valid range is from 0.000 to 55.000.
<code><kp>:= <f></code>	This parameter sets the Kp variable for the temperature control algorithm. The valid range is from 0.000 to 100.000.
<code><ki>:= <f></code>	This parameter sets the Ki variable for the temperature control algorithm. The valid range is from 0.000 to 0.100.
<code><Coff>:= <f></code>	This parameter sets the Cooling Off variable for the temperature control algorithm. The valid range is from 0.050 to 35.000.
<code><Con>:= <f></code>	This parameter sets the Cooling On variable for the temperature control algorithm. The valid range is from 0.000 to 35.000.
<code><delay>:= <f></code>	This parameter sets the Heat Delay variable for the temperature control algorithm. The valid range is from 0.000 to 50.000.
<code><Bon>:= <f></code>	This parameter sets the Booster On variable for the temperature control algorithm. The valid range is from 0.250 to 35.000.
<code><Boff>:= <f></code>	This parameter sets the Booster Off variable for the temperature control algorithm. The valid range is from 0.200 to 35.000.

5.7.15.9. CONFigure:SETUp?

This query command requests the current operating configuration for the temperature control algorithm. The response from the 5600 will be:

Setup **50.000, 10.000, 0.010, 0.050, 0.000, 0.100, 0.250, 0.200**

5.7.16. FETCh - MEASUREMENT DATA QUERY

This query command retrieves the measurement data. The form of the fetch command sequences are as follows:

- FETCh? <channel>
display data value for the requested channel (<channel >:= {A|B})
- FETCh:DIFFerence?
display the value of the selected difference calculation
- FETCh:HISTory?
display the block of saved data for the current history channel.

5.7.16.1. FETCh? <channel>

This query command requests from the 5600 the most recent data value. The response is in the displayed units.

<channel>:= {A|B} This parameter selects the thermistor input channel measurement to be displayed.

The 5600 response will be:

Channel A temperature **24.006** deg. C

Or

Channel A resistance **109.2836** ohms

5.7.16.2. FETCh:DIFFerence?

This query command responds with the value which would be displayed in the “Measurement Difference” window of the VF display. The response to this query command is:

DDD: xxx.xxx U

DDD is one of: Ctl
 Aux
 Aux – Ctl
 Ctl - Setpoint
 Difference value

U is one of: deg. C
 deg. F
 ohms
 K

5.7.16.3. FETCh:HISTory?

The response to this query command is a block of data of a maximum of 499 pairs of saved data. The verbose format of the response is:

Date/Time Wed Feb 01 10:45:11 1995, Ctl Ch aaaaaaaaaa, Aux Ch bbbbbbbbbbb, Sample Off, Interval 1, Sample Mode Continuous, Units C, Readings 499; xxx.xxx, yyy.yyy;...; xxx.xxx, yyy.yyy

Date/Time : time of the last sample in the list
 aaaaaaaaaa: serial number of the thermistor assigned to the Ctl Channel
 bbbbbbbbbbb: serial number of the thermistor assigned to the Aux Channel
 Sample: 0 = Off; 1 = On
 Interval: 1 to 2000
 Sample Mode: 0 = Continuous; 1 = Single sweep

Units:	C F O K
Readings:	number of data pairs to follow
xxx.xxx:	Ctl Channel value in units indicated
yyy.yyy:	Aux Channel value in units indicated

The terse format of the above response is:

Wed Feb 01 10:45:11 1995, “aaaaaaaaaaaa”, “bbbbbbbbbbbb”, 0, 1, 0, C, 499;
xxx.xxx, yyy.yyy;...; xxx.xxx, yyy.yyy

5.7.17. MEASure - SET/DISPLAY THE MEASUREMENT PARAMETERS

This command allows a system programmer to set/display the settings for the current measurement. The form of the measure command sequences are as follows:

```

MEASure:CALCulation <mode>
    select difference calculation mode (<mode>:= {0|1|2|3})
MEASure:CALCulation?
    display the difference calculation mode
MEASure:FILTer <state>,<function>,<size>
    setup the digital filter and select a filter size for the Aux Channel data
    (<state>:= {0|1}; <function>:= 0; <size>:= {3|4|...|50})
MEASure:FILTer?
    display the filter setup
MEASure:HISTory <state>,<rate>,<mode>
    set measurement history configuration (<state>:= {0|1};
    <rate>:= {1|2|...|2000}; <mode>:= {0|1})
MEASure:HISTory?
    display the measurement history configuration
MEASure:HISTory:CLEAr
    clear measurement history buffer
MEASure:SENSor <channel>,<sensor>
    assign an input (<channel>:= {A|B}) to a thermistor number
    (<sensor>:= {0|1|...|15})
MEASure:SENSor? <channel>
    display the thermistor number assigned to the input (<channel>:= {A|B})
MEASure:TREND <channel>
    reset trend data (<channel>:= {A|B})
MEASure:TREND? <channel>
    display the trend data (<channel>:= {A|B})
MEASure:UNIT <unit>
    select the units of measurement and instrument operation
    (<unit>:= {O|C|F|K})
MEASure:UNIT?
    display the units of measurement

```

5.7.17.1. **MEASure:CALCulation <mode>**

This command selects the difference calculation to be one of:

- 0 current Control Channel value
- 1 current Auxiliary Channel value
- 2 current Auxiliary Channel value minus current Control Channel value
- 3 current Control Channel value minus Setpoint value

5.7.17.2. **MEASure:CALCulation?**

This query command responds with the difference calculation mode. The verbose response is:

Difference Mode DDD

Where DDD is one of:

Ctl
Aux
Aux – Ctl
Ctl - Setpoint

The terse response is the number described above.

5.7.17.3. **MEASure:FILTer <state>,<function>,<size>**

This command turns on the digital filter algorithm used in the 5600. A simple moving average (<function> = 0) digital filter is selected by this command. The digital filter calculates the average of the last N readings where N is the value, between 3 and 50, assigned to <size>. To turn the filter function off, <state> should be set to 0. This function operates on both input data channels.

5.7.17.4. **MEASure:FILTer?**

This query command requests the value of the currently selected filter factor. The response from the 5600 will be:

Filter 1,0,25

Indicating that the filter is ON (1), and 25 readings are the assigned number of samples to be used by the simple average filter algorithm.

5.7.17.5. MEASure:HISTory <state>,<rate>,<mode>

This command sets the following parameters for the storing of measurement data:

<state> ::= 0	OFF (storage suspended)
::= 1	ON (storage enabled)
<rate> ::= <u>	the number of measurement samples averaged together and stored as one value (1 to 2000)
<mode> ::= 0	Continuous (oldest data is overwritten by new data)
::= 1	Single sweep (storage stops when buffer full)

5.7.17.6. MEASure:HISTory?

This query command responds with the configuration of the history function. The verbose response is:

Sample Off, Interval 50, Sample Mode Continuous

The equivalent terse response is:

0, 50, 0

5.7.17.7. MEASure:HISTory:CLEAr

This command clears the stored measurement data from the history buffer.

5.7.17.8. MEASure:SENSor <channel>,<sensor>

This command controls the assignment of a thermistor and its associated coefficients to an input channel of the 5600.

<channel> ::= {A B}	This parameter assigns the associated 5600 thermistor input channel.
<sensor> ::= {0 1 ... 15}	This parameter selects the thermistor number assigned from the SOFCAL:SENSor setup procedure. Coefficients for up to sixteen thermistors can be saved in the non-volatile memory of the 5600. The selected thermistor number can be one of 0 through 15.

This command is valid only when in the REMOTE state.

5.7.17.9. MEASure:SENSor? <channel>

This query command requests the current assignment of a thermistor number to an input channel of the 5600.

<channel> ::= {A B}	This parameter assigns the associated 5600 thermistor input channel.
---------------------	--

The response from the 5600 will be:

Aux Channel thermistor 3

Indicating that thermistor data set #3 is assigned to input Aux Channel.

5.7.17.10. MEASure:TREND <channel>

This command sets the trend data for the specified channel to the following:

Min	last displayed value
Max	last displayed value
Range	0
Std Dev	0
Drift	0

5.7.17.11. MEASure:TREND? <channel>

This query command responds with the trend data for the specified channel. The response is:

Channel A, Mode C, Min **24.107**, Max **24.218**, Spread **0.111**, Std **0.013**, Drift **0.001**

Indicating that this is the trend data for the Control Channel, displayed in degrees Celsius. The data are listed in order:

- minimum value since last reset
- maximum value since last reset
- spread between maximum and minimum values
- standard deviation of last n samples
- rate of change (units/second) of last n samples (n is the filter sample size).

5.7.17.12. MEASure:UNIT <unit>

This command selects the engineering units of measure to be used for all calculations performed by the 5600. The accepted units of temperature are C|CEL for degrees Celsius; F|FAR for degrees Fahrenheit; K|KEL for kelvins. For direct reading in ohms, the accepted command is O|OHM.

The units set by this command act globally and can be set once in any instrument setup operation.

The selected unit of operation for the 5600 is saved in non-volatile memory.

5.7.17.13. MEASure:UNIT?

This query command requests a report of the current setting of the engineering units of measure used for all calculations performed by the 5600.

The response from the 5600 will be:

Units CEL

Indicating that CELSIUS degrees are the assigned units of measure.

5.7.18. SOFCAL - SET 5600 CALIBRATION COEFFICIENTS

This series of commands allow a system programmer to set the operating calibration coefficients for the instrument.

WARNING

Great care should be taken when using this command since the 5600 cannot check that the values of the parameters are correct.

The form of the SOFCAL command sequences are as follows:

```
SOFCAL:CHANnel<channel>,<C0>,<C1>,<C2>
    set linearization coefficients (<channel>:= {A|B}; <C0>:= <f>;
    <C1>:= <f>; <C2>:= <f>)
SOFCAL:CHANnel?<channel>
    query linearization coefficients (<channel>:= {A|B})
SOFCAL:DATE <YYYY>,<MM>,<DD>
    set date of calibration
SOFCAL:DATE?
    display date of calibration
SOFCAL:SENSor<sensor>,<argument>
    program sensor parameters (<sensor>:= {0|1|...|15}; <argument> see below)
SOFCAL:SENSor?<sensor>
    query sensor parameters (<sensor>:= {0|1|...|15})
```

5.7.18.1. SOFCAL:CHANnel<channel>,<C0>,<C1>,<C2>

This command allows remote entry of the calibration coefficients for the two 5600 input channels A and B. When using this command the entries are as follows:

<channel> := {A B}	This parameter assigns the associated 5600 thermistor input channel.
<C0> := <f>	linearization coefficient 0
<C1> := <f>	linearization coefficient 1
<C2> := <f>	linearization coefficient 2

5.7.18.2. SOFCAL:CHANnel? <channel>

The SOFCAL query command allows the programmer to review the current values stored for instrument calibration of the selected thermistor input channel.

<channel> := {A|B} as above

The 5600 response will be:

Channel A coefficients: **0.000, 9.83000E-04, 0.000**

5.7.18.3. SOFCAL:DATE <YYYY>,<MM>,<DD>

This command is used to set the date of calibration of the 5600.

<DD> := <u> day of month (limited to range 1...31)

<MM> ::= <u> month of year (limited to range 1...12)
 <YYYY> ::= <u> year (limited to ranges 00...38, 70...99 and 1970...2038)

The range limits of the date of calibration are January 1, 1970 to January 19, 2038

5.7.18.4. SOFCAL:DATE?

This query command requests the date of calibration of the 5600.

The response will be:

Calibration date **1999,04,30**

5.7.18.5. SOFCAL:SENSor <sensor>,"s", S, a, b...

This SOFCAL command programs one of the 16 saved sensor configurations. The symbols for the argument passed are defined as follows:

<sensor> ::= <u> thermistor number (0 through 15)
 s ::= <string> thermistor serial number (max 11 characters)
 S ::= {0|1|2|3|4} temperature scale, defined as:
 4 Thermistor
 a, b... ::= <f> calibration coefficients, where the order and number of the coefficients depends on the temperature scale as follows:
 Thermistor A, B, C

5.7.18.6. SOFCAL:SENSor? <sensor>

This query command requests the current configuration settings for the thermistor associated with the data set <sensor>.

<sensor> ::= <u> thermistor number (0 through 15)

The verbose response is:

Thermistor n, SN "s", <S> Coefficients a, b, c

The terse response is:

n, "s", S, a, b, c

Where:

n thermistor number (1 through 16)
 s thermistor serial number
 S temperature scale description as listed above

5.7.19. SYSTem: - SET THE 5600 OPERATING PARAMETERS

This command allows a system programmer to set the operating parameters for the instrument. The form of the system command sequences are as follows:

```

SYSTem:COMMunicate:GPIB <address>,<mode>
    setup GPIB communications (<address> ::= {1|2|...|30}; <mode> ::= {0|1|2})
SYSTem:COMMunicate:GPIB?
    display the GPIB set up
  
```

SYSTem:COMMunicate:SERial <bd>,<dt>,<pr>,<st>,<pc>,<ch>,<md>
 setup RS232 communications to the following:

<bd>:== <u>	baud rate
<dt>:== {7 8}	data bits
<pr>:== {0 1 2}	parity
<st>:== {1 2}	stop bits
<pc>:== {0 1 2}	flow control
<ch> :== 	echo
<md>:== {0 1 2}	mode

SYSTem:COMMunicate:SERial?

display RS232 set up

SYSTem:DATE <YYYY>,<MM>,<DD>

set the current date

SYSTem:DATE?

display the current date

SYSTem:DIAGnostic:ROMChecksum?

display ROM checksum

SYSTem:DIAGnostic:SerialNUMBER <number>

assign unit serial number

SYSTem:DIAGnostic:SerialNUMBER?

display unit serial number

SYSTem:DIAGnostic:TEST? <number>

perform internal test and report result

SYSTem:KEY?

query last key pressed

SYSTem:LOCAL

enter the local state (RS232 command only)

SYSTem:LOCKOUT

enter the local lockout state (RS232 command only)

SYSTem:REMOTE

enter the remote state (RS232 command only)

SYSTem:TERSe

respond to commands with a minimum data set

SYSTem:TIME <hh>,<mm>,<ss>

set the current time

SYSTem:TIME?

display the current time

SYSTem:VERBose

respond to commands with a maximum data set

SYSTem:VERSion?

display the installed software version

5.7.19.1. **SYSTEM:COMMunicate:GPIB** <address>,<mode>

This command sets the operating address and mode of operation of the IEEE-488 communication interface.

<address>:= <u>	this parameter assigns the bus address and can take on any value in the range 1 to 30.
<mode>:= {0 1 2}	this parameter sets the mode of operation of the communication interface to one of: <ul style="list-style-type: none"> 0 disable the IEEE-488 interface. 1 enables TALK ONLY operation. 2 enable TALK/LISTEN capabilities.

This command does not become effective until the 5600 has been initialized by a power on reset.

5.7.19.2. **SYSTEM:COMMunicate:GPIB?**

This query command requests the setting of the IEEE-488 communication port of the 5600. The IEEE-488 address and mode setting are returned in response to this query. The response will be:

GPIB 8, 1

Indicating that the communication bus address is set to 08 and the mode of operation is TALK ONLY.

5.7.19.3. **SYSTEM:COMMunicate:SERial**

<bd>,<dt>,<pr>,<st>,<pc>,<ch>,<md>

This command configures the RS232 serial communication interface of the 5600.

<bd>:= <u>	this parameter allows setting of the communication data rate. Valid baud rates in the range 75 to 38400 are permitted.
<dt>:= {7 8}	this parameter sets the number of data bits in the data word.
<pr>:= {0 1 2}	this parameter sets the operation of the parity bit to one of: <ul style="list-style-type: none"> 0 NO parity 1 ODD parity 2 EVEN parity
<st>:= {1 2}	this parameter sets the number of stop bits in the data word.
<pc>:= {0 1 2}	this parameter sets the mode of pacing the data transmit and receive functions to one of: <ul style="list-style-type: none"> 0 no handshake 1 XON/XOFF handshaking 2 RTS/CTS hardware handshaking

<code><echo>::= {0 1}</code>	this parameter controls echo responses from the 5600.
<code><mode>::= {0 1 2}</code>	this parameter sets the mode of operation of the RS232 communication interface to one of: 0 disable the RS232 interface 1 enables TALK ONLY operation 2 enable TALK/LISTEN operation

5.7.19.4. **SYSTem:COMMunicate:SERial?**

This query command requests the setup of the serial RS232 communication interface of the 5600.

The verbose response from the 5600 will be:

```
RS232 Baud  19600,
Bits       8,
Parity     0,
Stop       1,
Pace       1,
Echo       0,
Mode       1
```

The terse response from the 5600 will be:

```
19600,8,0,1,1,0,1
```

5.7.19.5. **SYSTem:DATE <YYYY>,<MM>,<DD>**

This command is used to set the current run-time date of the 5600.

<code><DD>::= <u></code>	day of month (limited to range 1...31)
<code><MM>::= <u></code>	month of year (limited to range 1...12)
<code><YYYY>::= <u></code>	year (limited to ranges 00...38, 70...99 and 1970...2038)

The range limits of the date are January 1, 1970 to January 19, 2038

5.7.19.6. **SYSTem:DATE?**

This query command requests the date of calibration of the 5600. The response will be:

```
Date 1999, 04, 30
```

5.7.19.7. **SYSTem:DIAGnostic:ROMChecksum?**

This query command requests the checksum of the installed instrument read only memory. Since the checksum algorithm is quite involved, the 5600 microprocessor will compute the checksum in its "spare" time. Depending on bus activity, it can take up to 30 seconds to receive a response from this command.

In order to determine if the computation of the checksum is complete the programmer must wait for the CHK bit in the STATUS BYTE register to be set to one (1). It should be noted that the CHK bit will only be set once after the 5600 is powered on; hence simply waiting for the CHK bit to become set may not always work if the ROM checksum has been previously read. The response will be:

ROM checksum **72304**

5.7.19.8. **SYSTem:DIAGnostic:SerialNUMBER <number>**

This command accepts an integer in the range 0 to 1 000 000, this number will be reported in the serial number field of the *IDN? command.

5.7.19.9. **SYSTem:DIAGnostic:SerialNUMBER?**

This query command requests the unit serial number. This is the same number as is reported in the serial number field of the *IDN? command. The 5600 will respond:

Instrument Serial Number **12345**

5.7.19.10. **SYSTem:DIAGnostic:TEST? <number>**

This command will perform the requested internal self-test and report 0 if the test was a success (test result is within allowable limits). A non zero result determines the source of the failure.

<number>:= 0 memory test
 The memory test results are the sum of:
0 Pass
1 U202 ROM checksum failure
2 U203 ROM checksum failure
4 U201 NVRAM checksum failure

5.7.19.11. **SYSTem:LOCAL**

This command will place the 5600 into the local state. This command duplicates the IEEE-488 GTL message (See section 0). This command can only be sent from an RS-232C controller. There are no parameters for the LOCAL command.

5.7.19.12. **SYSTem:LOCKOUT**

This command will place the 5600 into the local lockout state. This command duplicates the IEEE-488 LLO message (See section 0). This command can only be sent from an RS-232C controller. There are no parameters for the LOCKOUT command.

5.7.19.13. **SYSTem:REMOTE**

This command will place the 5600 into the remote state. This command duplicates the IEEE-488 REN message (See section 0). This command can only be sent from an RS-232C controller. There are no parameters for the REMOTE command.

5.7.19.14. **SYSTem:TERSe**

This is the default mode for the 5600 after reset. Typically query commands will return very little extraneous information in terse mode. There are no parameters for the TERSE command.

5.7.19.15. **SYSTem:TIME <hh>,<mm>,<ss>**

This command is used to set the current run-time of the 5600.

<hh>:== <u>	hour of day (limited to range 0...23)
<mm>:== <u>	minute of hour(limited to range 0...59)
<ss>:== <u>	second of minute (limited to range 0...59)

5.7.19.16. **SYSTem:TIME?**

This query command requests the time of the 5600. The response will be:

Time 18,27,06

5.7.19.17. **SYSTem:VERBoSe**

The verbose command causes the output of all subsequent commands to contain additional information. This mode should be used for determining problems with programs and when the instrument is being used interactively. There are no parameters for the VERBOSE command.

5.7.19.18. **SYSTem:VERSion?**

This query command requests the instrument software version. This command can be used instead of the *IDN? command to report only the software version.

6. TROUBLESHOOTING, MAINTENANCE AND CHECKS

6.1. INTRODUCTION

This section covers troubleshooting, repair, maintenance and checks of the 5600 Bath.

CAUTION

Do not run the 5600 unless fluid completely covers the pump inlet which is located near the top of the tank.

6.1.1. Model 5600 Oil Recommendation

There are a number of different metrology grade mineral oils, from various manufacturers, that are suitable for a Guildline oil bath. The key specifications are:

Density at 15 Celsius, kg/m cubed = 850

Color, Saybolt = +30

Kinematic Viscosity, Cct@40 Celsius = 12.8

The original oil recommended and used by Guildline for oil baths was Marcol 72 or Marcol 7. However this oil is no longer manufactured. Guildline now uses Total Nevastane Clear 15 White Mineral Oil. It is manufactured in Canada by Total Lubricants in Laval Quebec.

Other equivalent oils, with their supplier, are:

Petro-Canada - WO10

Sonneborn - Carnation White Mineral Oil

Penreco - Drakeol 7 and Parol 70

Whitaker Oil - 70 White Oil USP

There is also Total Finavestan A80B oil which has a slightly higher viscosity than we recommend but its use should not affect stability of a Guildline oil or fluid bath by more than 1 mK.

NOTE that a 5600 Bath is configured at the factory for use with either oil or water/sea water/other fluid. A bath configured for water will work with oil but typically will not meet the stability specification.

6.1.2. Maintenance

Preventive maintenance is limited to checking the instrument operation, temperature control stability, set point accuracy, and cleaning.

6.1.3. Maintenance Guidelines and Schedule

The following section provides a guide to problem diagnosis and a schedule for maintenance. It is recommended that verification of the 5600 Bath be performed annually or whenever it is apparent that temperature control or accuracy may be out of specification. Under certain circumstances where verification fails then the 5600 Bath alignment should be checked and adjustments made as required. Specific verification procedures are provided in Section 6 of this manual.

Maintenance Item	Procedure	Interval
Error Messages	Follow guidelines in this section 6.1.4.	As may be required
System Setup and Other Warnings	Follow guidelines in this section 6.3.	As may be required
Temperature Control Failures	Check control set up parameters and perform verification checks	As may be required
General Checks	Check cooling and heater functions and fault indications	Every 3 months
Temperature Control Stability and Accuracy	Perform Verification Checks	Annually
Cleaning	Follow guidelines in this section	Every 3 months for Salt Water Annually for other liquids
5600 Bath Long Term Maintenance	Perform 5600 Bath Alignment Check and Calibration/Verification	Every 3 years

Table 6-1 : Maintenance Schedule

6.1.4. Error Messages

The 5600 Bath will display an error if there is no communication between the bath and the Laptop Computer. In the event of such a warning message, simply cycle the power of the bath (i.e. power switch at the back of the bath) to reset the communication.

6.1.5. Cleaning Guidelines

The 5600 Bath uses a fiberglass tank, special hoses, and stainless steel for all parts that are in contact with the fluid. If salt water is used with the 5600 Bath the following cleaning procedure is recommended for every three months. If another liquid is used with the 5600 then the following cleaning procedure is recommended on an annual basis.

Stainless Steel is a class of alloys which are primarily steel with other metals added, normally chromium, to limit rusting. The chromium in stainless steel when exposed to oxygen in the atmosphere forms a thin invisible layer called chromium oxide. This invisible layer covering the entire surface gives stainless steel its ability to resist stains and rust. If this layer is damaged rust is formed on the surface at the point of that damage. However, with a little cleaning and care the chromium oxide layer is self-healing.

Avoid damaging the chromium oxide layer by avoiding the use of cleaners that contain chlorides (fluorine, chlorine, bromine, iodine, etc.). Cleaners containing alcohol, ammonia or mineral spirits can also damage the protective layer. Do not use steel wool or steel brushes as minute particles of these carbon steel articles may adhere to the stainless and begin to rust. Avoid any caustic cleaners containing any of the above. If these compounds were to be used extreme care must be used to remove any and all traces of the cleaner as these chemicals damage the chromium oxide layer.

Stainless steel and the chromium oxide layer have improved rust resilience with proper cleaning. For everyday cleaning of non-oxidized soils, dust, dirt and fingerprints, a mild soap/detergent (dish detergent) and warm water solution should be used. Use the solution to remove the soil, rinsing with fresh water and a clean cloth, and dry completely. Another alternative is to clean with a recommended stainless steel cleaner such as Cerama Bryte Stainless Steel Cleaner.

Removal of oxidized stains and even “surface rust” can be done by using a paste made from baking soda and water or a cleaner that contains oxalic acid, such as Bar Keeper's Friend Soft Cleanser. If using baking soda and water, use a cloth or soft bristle brush, rub the baking soda in the direction of the grain. This may take a little effort but this will remove these soils. When cleaned, rinse with deionized or distilled water on a clean soft cloth. If using Bar Keeper's Friend, use only the liquid cleanser (free of grit) and be sure rub in the direction of the metal grain lines with a damp soft sponge. Rinse with deionized or distilled water on a clean soft cloth.

6.2. TANK DRAIN

A stopcock is located behind the grille (i.e. the door at the back of the bath, or the door at the back of the control unit for the 5600-300L model) on the right hand side. Place a suitable piece of flexible tubing over the nipple of the stopcock. Lift the black handle to a vertical position to open the valve.

6.3. TROUBLESHOOTING

SYMPTOM	POSSIBLE CAUSE AND CURE
No display, pump does not run	Over Temperature limit switch is open. Reset as per 6.4.
100 mK cycling	Fluid slowly cools 100 mK below set point, then rises rapidly to set point repeatedly: Booster heater works but control heater is not operating.
Heater lamp dark	Enter a set point well above the present fluid temperature. Lamp should light. Check: <ul style="list-style-type: none"> • lamp (pull up bottom cap) • fuse, inside right grille • control heater, is 30 Ω
50.36 in display	Built in digital thermometer is outputting mid-scale continuously because: <ul style="list-style-type: none"> • Platinum Sensor is open circuit • Ribbon cable connectors are loose.
± 199.99 in display	Fluid temperature is outside PRT operating temperature range of -10.00 $^{\circ}\text{C}$ to 163.00 $^{\circ}\text{C}$.
Red light on, temperature displayed normally	<ul style="list-style-type: none"> • Set point not yet entered • Power line interruption
Display blank, no temperature displayed	<ul style="list-style-type: none"> • Power not on • Fuse (Electronics) blown • Over temperature switch open • Ribbon connector loose

SYMPTOM	POSSIBLE CAUSE AND CURE
Display flickers randomly, Heater lamp is unsteady and compressor “chatters”	<ul style="list-style-type: none"> • Control PCB failure • low line voltage
No circulation, no pump sound but display lights:	<ul style="list-style-type: none"> • pump fuse
Pump runs but no flow:	<ul style="list-style-type: none"> • air locked, turn power off-on, or: • block inlet momentarily
No cooling	<p>Enter set points below and above 60 °C. Fan should start and stop. If not, check:</p> <ul style="list-style-type: none"> • compressor fuse • opto-isolator Z20 <p>Remove side grille. Make sure fluid temperature is actually below 60 °C. Enter a set point below 60 °C. Fan starts. Listen for compressor motor. If it shuts itself off, it has overheated. Turn 5600 off for 10 minutes.</p>
Compressor starts, still no cooling	<p>Remove side grille. Upper right hand corner of radiator should be notably warmer while compressor runs. If not:</p> <ul style="list-style-type: none"> • recharge with R134a refrigerant as per drawing 17573.01.23 <p>Control fluid temperature at 39.99 °C. Adjust refrigerant pressure so that heater power level is about 50 %.</p>
Fluid temperature unstable	<p>Temperature varies around set point</p> <ul style="list-style-type: none"> • ambient temperature changes too fast • see 100 mK cycling • no lid • no grilles, or grilles blocked • too much evaporation • local freezing in heat exchanger <ul style="list-style-type: none"> • add glycol or antifreeze for temperatures < 5 °C • unsuitable fluid <ul style="list-style-type: none"> • note factory configuration is different for oil versus water • radio frequency interference intermittent

Slow heating

Enter present fluid temperature as a set point. Let stabilize. Enter a set point 0.09 °C warmer and note the heating rate. Enter a set point 0.11 °C warmer, heating should be twice as rapid. Booster heater is not on. Check:

- booster heater is 33 Ω
- there should be no path to earth from the booster

Display reads -111.11
SOFCAL

coefficients have unreasonable values, see SOFCAL bus command.

My set point was changed
to 23°C

If this occurred on power up, the cause is a non-volatile memory failure. See the SOFCAL bus command.

If this occurred during operation, then you have experienced a brownout and the set point in memory was lost. In both cases, 23 °C is the bath's safe default that will be used.

6.4. OVER TEMPERATURE RESET

A temperature limit switch is mounted to the top end of the heat exchanger. If the temperature of the heat exchanger reaches 60 °C this switch will disconnect the AC power from the 5600. To reset the temperature limit switch let the fluid temperature drop below 55 °C. Insert a blunt rod, such as a pencil, into the access hole of the back grille. Push until a definite click is felt.

6.5. HEATER REPLACEMENT

It is suggested that the unit is sent to the factory for the replacement of heaters. However in an emergency this repair can be made in the field. Before replacing any heater check the resistance of each heater in the following manner:

- Unplug the line cord
- Remove rear grille
- Loosen the three screws on the bottom left hand side of the terminal block. Remove the two white wires (Booster heater) and check if the resistance measures approximately 33Ω for 120 V units. Remove the two red wires (Control heater) and check if the resistance measures approximately 30Ω for 120 V units.
- Next check if there is a ground fault i.e. the resistance is less than $1 M\Omega$ between either wire and the metal bulk head.

If the circuit is open circuited, grounded or shorted, replace as follows:

- Drain liquid from 5600.
- Remove cover plate over heat exchanger (immediately behind grille)
- Carefully cut out foam insulation from top of opening to expose top of heat exchanger. Watch out for wires!
- Remove enough insulation until pipe fittings and wire connectors are exposed.
- Disconnect heater wires
- Loosen and remove compression fittings by turning the hexagonal nut counter-clockwise.
- Withdraw heater. Care should be taken not to lose the two ferrules inside the hexagonal nut!
- Install a new stainless steel cartridge heater. Specify voltage and wattage when ordering.
- Slide the nut, the short ferrule, and finally the conical ferrule over the new heater.
- Insert heater into heat exchanger. Push heater in until the last 5 mm protrude from the fitting and tighten with a wrench.
- Reconnect the heater wires.
- Replace the black plastic tube on the red rubber cap and hold it in position. Fill the cavity with a two part polyurethane foam and trim excess with a knife.
- Reconnect the wires to the terminal block, carefully retaining both the red and white wires under the third screw. Be careful not to pinch off the bare wire by over tightening the screws.
- Replace rear grille.
- Set upright and fill 5600 with liquid before turning power on.

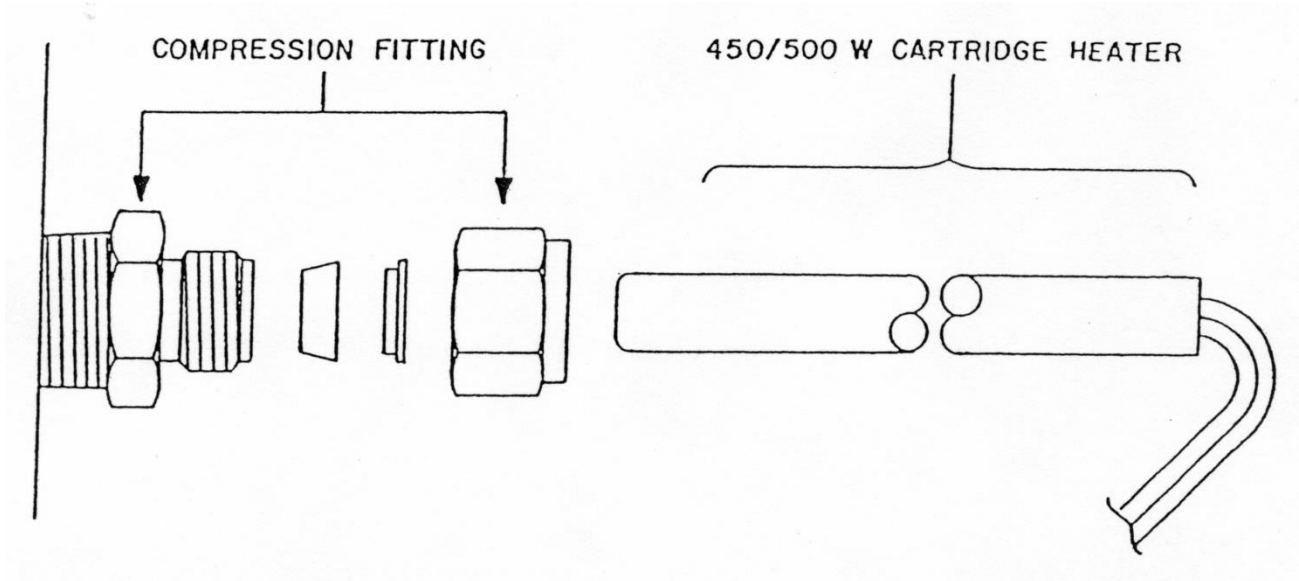

Figure 6-1 : Heater Replacement

7. APPENDICES

7.1. GENERAL SPECIFICATIONS

5600 SPECIFICATIONS (ALL MODELS)			
Temperature Range	Water: 3 °C to 55 °C		Oil: 5 °C to 55 °C
	Saltwater: 1 °C to 55 °C		alcohol and ethylene glycol: 0 °C to 55 °C
Temperature Set Point Accuracy ¹	± 0.01 °C over 24 hours, ± 0.05 °C over 1 year		
Set Point Resolution	0.0001 °C	Display Resolution	0.0001 °C
Temperature Stability	Oil		Water
Set point 23 °C ± 2 °C	± 0.0015 K		± 0.001 K
12 °C to 21 °C ◀ Set point ▶ 25 °C to 35 °C	± 0.004 K		± 0.003 K
8 °C to 11 °C	± 0.02 K		± 0.01 K
Temperature Uniformity ²	± 0.002 K relative to chamber center, 5 cm minimum from walls		
Temperature Attenuation	± 0.0015 °C/°C of ambient temperature		
Heating Rate (Typical)	Dependent on Bath size, fluid type and viscosity. Refer to Manual		
Cooling Rate (Typical)	Dependent on Bath size, fluid type and viscosity. Refer to Manual		
Cold Power On Stabilization	1 hour to within ± 2 mK of set point at ambient set point		
Temperature Monitor Accuracy	± 0.01 °C		
Temperature Monitor Resolution	0.0001 °C		
Over Temperature Protection	Programmable, Automatic shutdown if temperature > 60 °C ± 4 °C		
Maximum Power Dissipation of unit under test (set point above ambient)	10 W maximum		
Temperature Operating	50 °F to 95 °F		10 °C to 35 °C
Temperature Storage	-4 °F to 140 °F		-20 °C to 60 °C
Storage Humidity	< 90 % RH	Operating Humidity	-10 % to 60 % RH 20 °C to 60 °C

1 - Set Point Accuracy and Stability is defined as the deviation of the mean hourly value from the 24 hour mean for a single ambient temperature point at one point in the bath chamber (typically the center).

2 - Temperature Uniformity is relative to the center of the bath chamber and at least 5 cm from the bottom or sides of the chamber. Specification applies to 5 °C to 40 °C.

NOTE that the 5600 Bath is configured at the factory for use with oil OR water/salt water/other fluids.

Table 7-1 : General Specifications

Specifications (Continued)

	5600-75L (LxWxD)		5600-100L (LxWxD)	
Tank Capacity	19.8 gal	75 L	26.4 gal	100 L
Tank Size	27.0 x 13.5 x 12.8 in	68.6 x 34.3 x 32.5 cm	27.0 x 13.5 x 16.6 in	68.6 x 34.3 x 42.2 cm
Exterior Size	54.2 x 24 x 21.2 in	137.7 x 61 x 53.8 cm	54.2 x 24 x 21.2 in	137.7 X 61 x 53.8 cm
Weight ³	170 lbs	77.3 kg	180 lbs	81.8 kg
Power (VAC)	100, 115, 220, 230, 240- ±10 % / 50 or 60 Hz ± 10 %			

	5600-300L Mechanical Unit⁴ (L x W x D)		5600-300L Tank Unit⁴ (LxWxD)	
Tank Capacity ⁵	-	-	79.3 gal	300 L
Tank Size	-	-	39.4 x 25 x 20.5 in	100.1 x 63.5 x 52.1 cm
Exterior Size	30.3 x 21.3 x 25.7 inches	76.8 x 54.0 x 65.2 cm	55.2 x 30.3 x 28.6 in	140.3 x 76.8 x 72.7 cm
Weight ³	250 lbs	114 kg	325 lbs	148 kg
Power (VAC)	100, 115, 220, 230, 240- ±10 % / 50 or 60 Hz ± 10 %		-	

3 - Model weight does not include any fluids.

4 - 300L Bath consists of a Tank Unit and a Mechanical Unit for the pump, compressor and heat exchanger. Dimensions are for each unit.

5 - Tank Capacity is with the chamber filled with water or oil, but no standards immersed. Actual capacity may be slightly more due to pump and tubes within the Bath.

Table 7-2 : Model Specifications

7.2. TEMPERATURE CALCULATION

The microprocessor converts the raw A/D converter value to resistance using the channel calibration coefficients. There are separate coefficients for each channel and are calculated by:

$$R = C_0 + C_1X + C_2X^2$$

The microprocessor then converts the calculated resistance to temperature using the following algorithm. The particular algorithm used depends on the calibration assigned to the thermistor attached to that specific channel.

In the following equation, these variables have the meaning:

R_t thermistor resistance at the temperature being measured

t temperature in degrees Celsius

T temperature in Kelvin ($T = t + 273.15$)

All other variables are coefficients specific to that temperature scale

7.2.1. THERMISTOR

This temperature calculation uses absolute resistance rather than resistance ratio. This calculation uses the coefficients A , B , and C which are unique to that specific thermistor. The nominal values of these coefficients for a 2252 Ω thermistor are:

$$A = 1.47170E-03$$

$$B = 2.37583E-04$$

$$C = 1.04934E-07$$

The temperature in Kelvin is calculated as:

$$T = \left[A + B \ln(R_t) + C(\ln(R_t))^3 \right]^{-1}$$