



Model 9334A Series

Precision Resistance Standards

Technical Manual

NOTICE

The contents and information contained in this manual are proprietary to Guildline Instruments Limited. They are to be used only as a guide to the operation and maintenance of the equipment with which this manual was issued and may not be duplicated or transmitted by any means, either in whole or in part, without the written permission of Guildline Instruments Limited.

**TM9334A-G2-00
18 October, 2023**

Table of Contents

1.0	Introduction	1-1
1.1	Unpacking and Inspection	1-1
1.2	Warranty	1-2
1.3	To Obtain Warranty or Calibration and Repair Service	1-3
1.4	Safety Information	1-4
2.0	9334A Series Standard Specifications	2-1
2.1	9334A Model Series Uncertainty Specifications	2-1
3.0	Overview	3-1
3.1	General	3-1
3.2	Series Design Layouts	3-3
3.2.1	1 $\mu\Omega$ to 100 $\mu\Omega$ Standard Values	3-3
3.2.2	0.001 Ω to 1 M Ω Standard Values	3-4
3.2.3	10 M Ω to 100 G Ω Standard Values	3-5
3.2.4	“H” and “W” Standard Case Styles	3-5
3.3	Custom Values	3-7
4.0	Calibration and Performance Verification	4-1
4.1	Introduction	4-1
4.2	Calibration Overview	4-1
4.3	Calibration Interval and Performance	4-2
4.4	Calibration Temperature Point	4-2
4.5	Equipment and Standards Required for Calibration	4-3
4.5.1	Normal Ohms Calibration Standards (0.1 Ω to 100 k Ω)	4-3
4.5.2	Low Ohms Calibration Standards (1 $\mu\Omega$ to 0.1 Ω)	4-4
4.5.3	High Ohms Calibration Standards (100 k Ω to 1 G Ω)	4-4
4.5.4	Ultra High Ohms Calibration Standards (>1 G Ω)	4-5
4.6	Routine Calibration	4-6
4.7	Low Ohms Calibration	4-8
4.8	Normal Ohms Calibration	4-9
4.9	High Ohms Calibration	4-10
4.10	Ultra-High Ohms Calibration	4-11
5.0	Maintenance	5-1
5.1	Replaceable Parts	5-1
5.1.1	Common Parts (All Models)	5-1
5.1.2	Terminals 0.001 Ω to 100 G Ω	5-2
5.1.3	Terminals 100 $\mu\Omega$ and Less	5-2
5.1.4	AH and AW Series Terminals	5-2

List Of Figures

FIGURE 1 - 9334A SERIES.....	3-1
FIGURE 2 - RESISTANCE ELEMENT BUILD UP	3-2
FIGURE 3 - 9334A SERIES FROM 1 $\mu\Omega$ TO 100 μOHM	3-3
FIGURE 4 - 9334A SERIES FROM 0.001 Ω TO 1 $\text{M}\Omega$	3-4
FIGURE 5 - 9334A SERIES FROM 1 $\text{M}\Omega$ TO 100 $\text{G}\Omega$	3-5
FIGURE 6 - EXAMPLE "H" CASE	3-5
FIGURE 7 - "H" CASE LAYOUT.....	3-6
FIGURE 8 - "W" CASE LAYOUT.....	3-6

List Of Tables

TABLE 1 - 9334A MODEL SERIES UNCERTAINTY SPECIFICATIONS	2-1
TABLE 2 - LIST OF RECOMMENDED TEST CURRENTS OR VOLTAGES FOR RESISTANCE VALUES	4-7
TABLE 3 - CALIBRATION DATA WORKSHEET	4-12
TABLE 4 - TERAOHMMETER CALIBRATION DATA WORKSHEET	4-13

1.0 INTRODUCTION

This manual provides an overview of the 9334A Series of Air Resistance Standards and also contains the necessary information required to perform a calibration or verification test. General product information, description of case styles and performance specifications are also included.

This manual applies to all models of the 9334A Series of Resistance Standards unless otherwise noted. This includes custom values that are ordered.

The phone number in the USA and Canada to obtain Product Support, Calibration Service or Replacement Parts is (800) 310-8104.

To Contact Guildline Instruments, the following information is provided.

USA and Canada Telephone: (613) 283-3000

USA and Canada Fax: 1-613-283-6082

Outside US and Canada Telephone: + [0] [1] 613 283-3000

Outside US and Canada Fax: + [0] [1] 613 283-6082

You can also contact Guildline Instruments Limited via their Email or Websites.

Email is: sales@guildline.com

Website is: www.guildline.com

1.1 Unpacking and Inspection

Every care is taken in the choice of packing material to ensure that your equipment will reach you in perfect condition. If the equipment has been subject to excessive handling in transit, the fact will probably be visible as external damage to the shipping carton.

In the event of damage, the shipping container and cushioning material should be kept for the carrier's inspection.

Carefully unpack the equipment and check for external damage to the standard. If the shipping container and packing material are undamaged, they should be retained for use in return shipments. If damage is found notify the carrier and Guildline immediately.

1.2 Warranty

Guildline Instruments warrants its products to be free of defects in manufacture and normal operation for a period of two (2) years from the date of purchase, except as otherwise specified. This warranty applies only in the country of original purchase and only to the original purchaser, who is also the end user. Equipment, which is defective or fails within the warranty period, will be repaired or replaced at our factory without charge at the discretion of Guildline Instruments.

In addition, standards and systems manufactured by Guildline Instruments are warranted to be free of defects in overall system operation for a period of two (2) years from the date of receipt by the original purchaser.

Third party system components purchased by Guildline carry the warranty of the original equipment manufacturer and will be accepted for claim by Guildline Instruments at our factory only after warranty authorization by the original manufacturer.

Limitation of Warranty

Warranty coverage does not apply to equipment which has failed due to misuse, neglect, accident or abnormal conditions of operation or if modifications or repairs have been made without prior written authorization of Guildline instruments.

Temperature probes are not warranted against failure due to mechanical shock.
Fuses, lamps and non-rechargeable batteries are not warranted against breakage.

Damage in Shipment to Original Purchase

Instrument(s) should be thoroughly inspected immediately on receipt for visible damage. Any damage should be reported to the carrier and further inspection and operational tests should be carried out if appropriate to determine if there is internal damage. Contact Guildline Instruments before returning for repair. The Customer or purchaser must complete all final claims with the carrier.

Regular charges will apply to non-warranty service. External service charges and expenses will be billed at cost plus handling.



Section 1

1.3 To Obtain Warranty or Calibration and Repair Service

Call for a Return Material Authorization (RMA) number. RMA's are required for all Warranty Returns and/or Calibration and Repair Service Requests. Telephone, Fax and email addresses to contact Guildline are provided previously.

Guildline Instruments will pay for all warranty costs including shipping from Guildline to the original shipment point. However, if the instrument is purchased within one country and shipped to another, Guildline will only pay for shipping to the original ship to country or customer point. The customer is responsible for paying for the shipping costs to return an item to Guildline.

USA Warranty Return Address.

USA Customers should use the following address to return instruments for warranty service or calibration support.

Guildline Instruments Limited
C/O AN Deringer
835 Commerce Park Drive
Ogdensburg, NY 13669

Mark on the outside of the box:

RMA # _____

Model # _____

Serial # _____

The Statement: "Canadian manufactured goods being returned for repair."

For all other countries, including Canada please ship to:

Guildline Instruments Limited
21 Gilroy Street, PO Box 99
Smiths Falls, ON K7A 4S9

Mark on the outside of the box:

RMA # _____

Model # _____

Serial # _____

The Statement: "Canadian manufactured goods being returned for repair."

1.4 Safety Information

These Standards can be used with Equipment capable of voltages up to 1000 V. The operator should be aware of the environment in which these standards are used.

WARNING: Use caution when working with voltages above 30 V ac rms, 42 V ac peak, or 42 V dc. These voltages pose a shock hazard.

The 9334A Resistance Standards are designed to work within specifications to 100 mW of power and 1000 Vdc or less. Applying more than the recommended power or voltage will damage the unit and voids the warranty.

Do not use the Resistance Standard in wet environments.

Never use the Resistance Standard with the cover removed or the case open.

When making electrical connections, connect the common test lead before connecting the live test lead; when disconnecting, disconnect the live test lead before disconnecting the common test lead.

Inspect the Resistance Standard for damage such as cracked connectors prior to use. If unit has a burned smell or smoke is visible during use, discontinue use immediately.

If test equipment used with Resistance standards overloads or trips, this could be a sign that the resistance standard requires repair..

Inspect all test leads used with the Resistance Standard for damaged insulation or exposed metal. Check all test leads for continuity.

Ensure all test leads are correctly connected prior to applying current or voltage.

Do not use resistance standards around explosive gas, vapor or dust.

2.0 9334A SERIES STANDARD SPECIFICATIONS

2.1 9334A Model Series Uncertainty Specifications

Table 1 shows the specifications for the 9334A series. For custom models, please consult your calibration certificate to determine stabilities and maximum limits.

Table 1 - 9334A Model Series Uncertainty Specifications

Low to Ultra Low Values (4-Wire Configurations)

Model (Nominal Ω)	Initial ¹ Tolerance \pm ppm	Stability (\pm ppm) ²		Maximum Limits		Temperature Coefficient \pm ppm/ $^{\circ}$ C	Voltage ⁴ Coefficient \pm ppm/ V_{dc}
		Initial 12 Months ³	2 nd Year ³	Current (A)	Voltage (V)		
9334A-1 μ	500	250	50	100	0.0001	50	NA
9334A-10 μ	200	100	25	50	0.0005	25	NA
9334A-100 μ	50	25	15	20	0.002	8	NA
9334A-0.001	20	15	10	6	0.01	1.5	NA
9334A-0.01	10	10	5	3	0.03	0.5	NA

Mid-Range Values (4 Wire Configurations)

Model (Nominal Ω)	Initial ¹ Tolerance \pm ppm	Stability (\pm ppm) ²		Maximum Limits		Temperature Coefficient \pm ppm/ $^{\circ}$ C	Voltage ⁴ Coefficient \pm ppm/ V_{dc}
		Initial 12 Months ³	2 nd Year ³	Current (mA)	Voltage (V)		
9334A-0.1	5	2.5	2.5	1000	0.1	0.3	NA
9334A-1	2	2.5	2.5	320	0.32	0.2	NA
9334A-10	2	2.5	2.5	100	1	0.2	NA
9334A-25	2	2.5	2.5	64	1.6	0.2	NA
9334A-100	2	2.5	2.5	32	3.2	0.2	NA
9334A-400	2	2.5	2.5	16	6.3	0.2	NA
9334A-1k	2	2.5	2.5	10	10	0.2	NA
9334A-10k	2	2.0	2.0	3.2	32	0.2	0.01
9334A-100k	3	2.5	2.5	1	100	0.3	0.03
9334A-1M	5	4	4	.32	320	0.3	0.05

High to Ultra High Values (2 Wire Configurations)

Model (Nominal Ω)	Initial ¹ Tolerance \pm ppm	Stability (\pm ppm) ²		Maximum Limits		Temperature Coefficient \pm ppm/ $^{\circ}$ C	Voltage ⁴ Coefficient \pm ppm/V _{dc}
		Initial 12 Months ³	2 nd Year ³	Current (μ A)	Voltage (V)		
9334A-10M	15	5	5	100	1000	2.5	0.1
9334A-100M	35	20	10	15	1500	6	0.2
9334A-1G	50	25	10	1.5	1500	6	0.3
9334AH-1G	50	25	10	1.5	1500	6	0.3
9334AW-1G	50	25	10	1.5	1500	6	0.3
9334A-10G	100	100	20	0.15	1500	25	0.5
9334AH-10G	100	100	20	0.15	1500	25	0.5
9334A-100G	350	200	50	0.015	1500	250	1

Note 1: Nominal initial tolerance is defined as the maximum variation of resistance mean values as initially adjusted at the point of sale.

Note 2: Calibrated in air at 23 $^{\circ}$ C traceable to the SI unit of electric resistance, calibration uncertainties expanded and expressed at the 95 % level of confidence. An ISO/IEC 17025 accredited certificate and report of calibration stating the calibrated value and estimated uncertainty is provided with each resistor..

Note 3: Initial 12 month drift is for first year of ownership only. The initial 12 month drift is higher due to stabilization of elements. After the initial 12 months, the two year specification is used as the maximum yearly drift specification.

Note 4: Voltage hysteresis: negligible to < 0.1 ppm. Temperature hysteresis: < 0.3 ppm between 0 $^{\circ}$ C and 40 $^{\circ}$ C

Note 5: Special/Custom Values available upon request including 1.9x values.

Note about Voltage and Temperature coefficients.

The Standards used for calibration are capable of much higher voltages that typically found on common instruments used with these resistance standards. For example, a 9334A-100M is calibrated by Guildline with the value reported at 100 V. If this 100M was connected to a Keysight (Agilent) 3458A, the DMM is only capable of 5 V at 100 M and 1G Ω . This means that there is a 95 V Voltage coefficient minimum that must be added to the expected results when comparing results from the two voltages used. Taking 95 x 0.5 ppm/Volt (i.e multiply by the Voltage Coefficient) you have an additional adder of 47.5 ppm that must be added to the measurement result.

With a Fluke 8508, special care must be taken as to understanding the type of stimulus being presented to the Resistor under test. According to Fluke operators manual, in Lo Current mode, for 200M, the current used is 10 nA. This means that the maximum voltage available would be 10 nA x 100 M or 0.1 V. In the High Voltage mode, the current is increased to 1 μ A

or an available voltage of 100 V. If the user is not aware of these modes, there is a potential of a 50 ppm error due to selecting the wrong mode of operation on the 8508.

Temperatures greatly affect high to ultra high resistance values. In some cases a single degree of temperature can affect a high value resistor by as much as 80% of the standards drift specification. Special care must be given to calibration in a stable temperature environment. Additionally, care must be given to ensuring that the temperature coefficient uncertainty is accounted for when the calibration temperature is more than 1°C from the usage temperature.

2.2 General Specifications

Environmental					
Operating Temperature	18 °C to 28 °C				
Operating Humidity	15 % to 70 % RH non-condensing (Values ≤1 MΩ)				
	15 % to 50 % RH non-condensing (Values ≥10 MΩ)				
Storage Temperature	-20 °C to 60 °C				
Storage Humidity	15 % to 80 % RH non-condensing				
Dimensions	Models >100 μΩ			Models ≤ 100 μΩ	
	Height	88 mm	3.5"	97 mm	3.8"
Width	124 mm	4.9"	124 mm	4.9"	
Depth	79 mm	3.1"	79 mm	3.1"	
Weight	.63 kg	1.4 lbs	1.1 kg	2.4 lbs	
Shipping Weight	1 kg	2.2 lbs	2 kg	4.4 lbs	

3.0 OVERVIEW

3.1 General

The Guildline Model 9334A series of Resistance Standards are designed as very high stability calibration laboratory standards for high accuracy resistance calibration in air, between $1 \mu\Omega$ and $100 \text{ G}\Omega$, without the need for stabilization in a temperature controlled bath (see Figure 1). If necessary, the ambient temperature adjacent to the enclosure may be monitored, and a correction factor applied to the value of the resistance.

The 9334A Resistance Standards are the worlds most accurate air resistance standards available today. During manufacturing, the temperature coefficients are verified by actually measuring each standard at 3 temperature points (i.e. at 21°C , 23°C , and 25°C) using a primary level Direct Current Comparator Bridge and an air or oil bath. This ensures that the resistance standard meets the published temperature coefficient specification over the standards recommended range. For example at $10 \text{ k}\Omega$, with a wide laboratory environment of 23°C with control to $\pm 3^\circ\text{C}$, the worse case effect due to temperature will be a remarkable 0.2 ppm !

The 9334A Series can be used as working standards, or highly reliable and rugged transportable transfer standards. They are extremely useful for the calibration of the resistance ranges of multi-function calibrators and high accuracy digital multimeters, as well as for use in more classical standards and calibration laboratory applications where the need for high accuracy resistance values are required.

If linearity verification of a long scale DVM is your challenge, $1.9\times$ cardinal resistance points are available. If you require any value between $1\mu\Omega$ and $100 \text{ G}\Omega$, Guildline can supply a precision standard to fulfill your requirement.

Figure 1 - 9334A Series



Models are also available to verify Temperature Measurement instruments such as Super Thermometers. Special Standard values such as 0.25 Ω , 25 Ω , 200 Ω and 400 Ω are available for precision thermometry applications. 9334A Resistance Standards available for Quantum Hall Effect applications include 6.4532 k Ω and 12.9064 k Ω .

The design of Guildline’s 9334A Series Resistance Standards is based on over 58 years of innovation, design knowledge, and manufacturing experience in building resistance standards. Guildline resistance standards are made with multiple elements in parallel or series rather than using a single element as per competitive products.

This approach lowers the drift that is seen with a single element and reduces the internal noise generated inside the reference resistor. The result is industry leading annual drift rates.

The design starts with every resistance element going through an exacting process that ensures quality and long term stability. This process is diagrammed as shown:

Figure 2 - Resistance Element Build Up

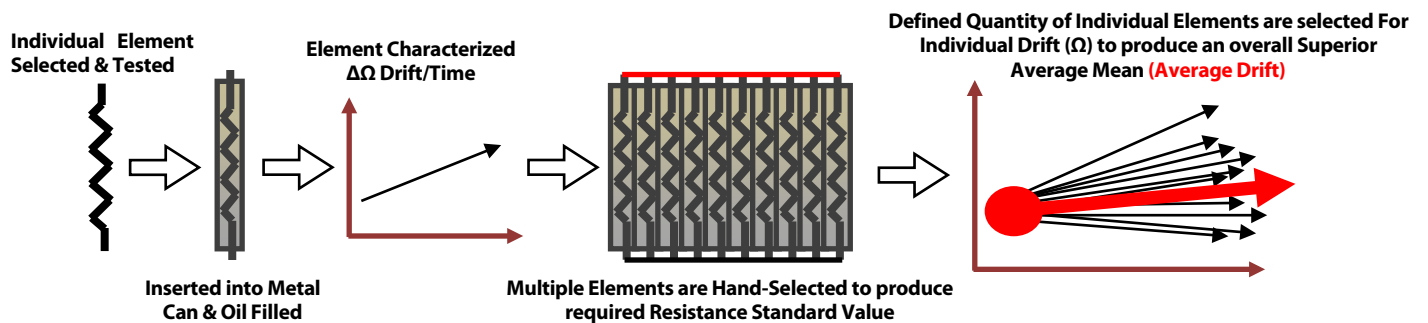

The multiple elements are sealed in epoxy for protection against humidity, are bonded to a thermal block, and are placed into the provided EMI shielded outer case with high quality terminals attached.

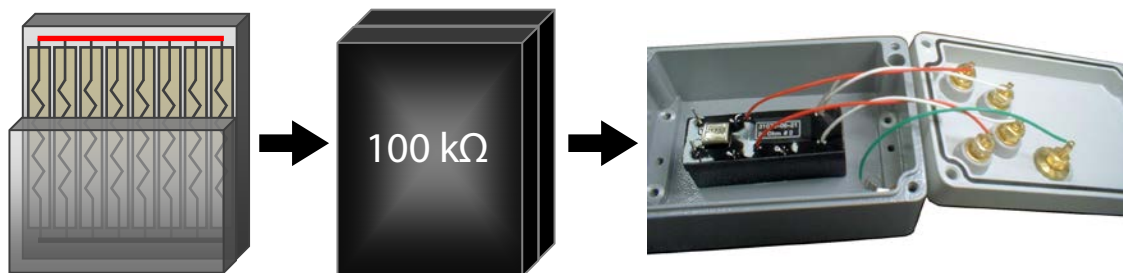

Guildline standards are the best by design and by manufacture. One key advantage of Guildline Resistance Standards is that each Resistance Value is made up from multiple resistance elements, not just a single element which is the technique used by most manufacturers.

The 9334A Series are designed for use with Direct Voltage or Direct Current. For AC Voltage and AC Current applications see our 7334A Series of AC Resistance Standards and 7340 / 7350 Series of AC Shunts.

3.2 Series Design Layouts

3.2.1 1 $\mu\Omega$ to 100 $\mu\Omega$ Standard Values

The resistor element is securely mounted to the inside of a hermetically sealed aluminum enclosure. The large C1 and C2 connectors are used for current connections and can handle currents up to 100 Amperes (refer to Figure 2). The P1 and P2 connections are used to measure the voltage drop across resistance. The fifth (gold) connector is for chassis ground. A diagram is provided in figure 2.

It is recommended that the operator use proper current leads and connectors that can handle the appropriate amount of current being conducted across the resistance standard. For example, Lead Set 92302 is required when sourcing 100 Amperes of current across the "C1" and "C2" connectors to avoid conducting thermal energy into the resistance element through the terminal connection.

Figure 3 - 9334A Series from 1 $\mu\Omega$ to 100 $\mu\Omega$

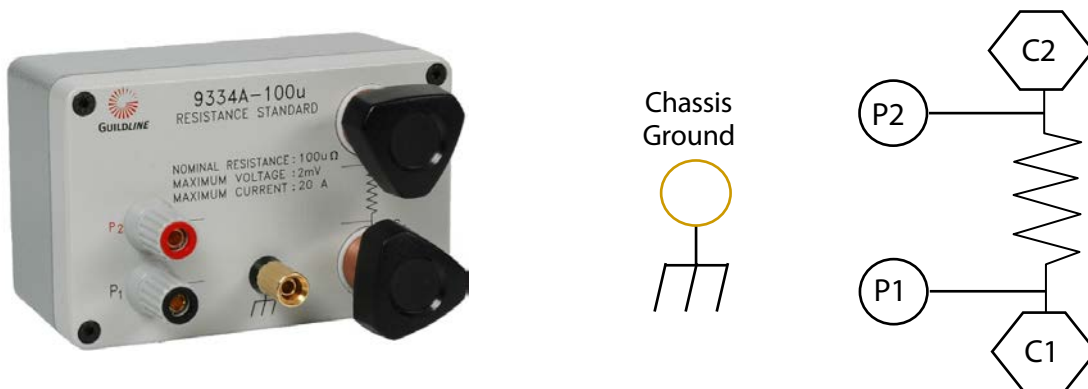

3.2.2 0.001 Ω to 1 M Ω Standard Values

The resistor elements are securely mounted to the inside of a hermetically sealed aluminum enclosure. For resistances up to 1 M Ω , five binding post connections on the top of the resistance standard are provided (refer to Figure 2). The C1 and C2 connections are used to apply the test current or voltage to the resistor. The P1 and P2 connections are used to measure the voltage drop and thus the resistance. The fifth connection is for chassis ground.

Figure 4 - 9334A Series from 0.001 Ω to 1 M Ω

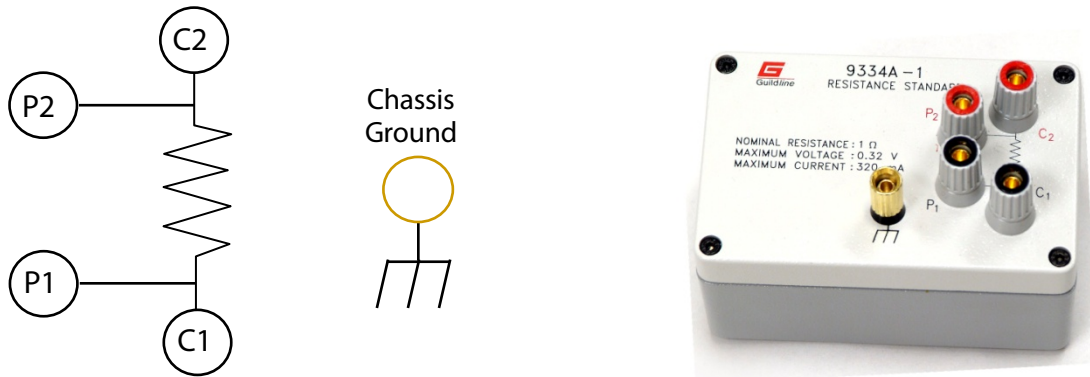

3.2.3 10 MΩ to 100 GΩ Standard Values

For resistances greater than 1 MΩ, three binding post connections on the top of the resistance standard are provided (see Figure 3). The P1 and P2 connections are used to both apply the test voltage to the resistor and to measure the resistance. The third connection is for chassis ground. The schematics in Figures 4 and 5 also appear on the top of the respective enclosures and identify the internal connections of the Model 9334A to the banana plugs as viewed from the plug side of the enclosure.

Figure 5 - 9334A Series from 1 MΩ to 100 GΩ

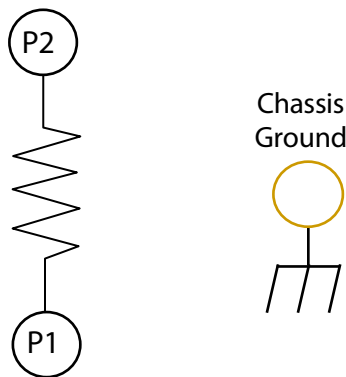

3.2.4 "H" and "W" Standard Case Styles

In high resistance measurements, cables can pick up electrical noise. Air movement around the cables can also significantly impact the measurement reading stability. By plugging a resistance standard directly into the front panel of an instrument, resistance measurement stability is greatly enhanced and errors associated with cabling are removed.

The 9334A Line of Standard Resistors now offers a series of Direct Plug-In Models for calibration and verification of High End Performance Digital Multimeters (DMM's). These include the Keysight/Agilent/HP 3458A Series, the Fluke 8508 Series, and the Wavetek/Datron 1281/1271 Series of DMM's.

Figure 6 - Example "H" Case



These special 6 terminal 9334A's are design to fit or "Plug" directly into the DMM's input terminals eliminating the need for external leads and the inherent problems of lead noise pickup.

The "H" Series of 9334A's incorporate terminal spacing for the Agilent/HP and Fluke series of DMM's. Because of its universal design, this Direct Plug In Series will work for either 2 terminal measurements or 4-wire measurements for any of these meters. The layout for the individual resistors (H and W) are marked on each resistor cases.

The H case style is also available in any value from 1 mΩ to 100 GΩ. Guildline has produced these values in slightly different terminal spacing to accomodate Artifact Values of 1 Ω and 10 kΩ for Fluke 57XX Series of Calibrators.

Note: The Fluke 8508 is capable of sourcing voltages up to 200 V. Extreme care should be used when sourcing voltages greater than 40 V.

The 9334A"W" Series have the same specifications as the "H" series. However, due to the slight differences in the Wavetek/Datron DMM's input terminal spacing, the "W" Model will only work with this series of DMM's. Refer to Figure 6 For "H" case style resistance layout and Figure 7 shows "W" case style resistance layout.

Figure 7 - "H" Case Layout

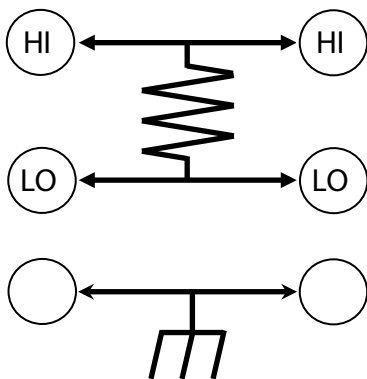
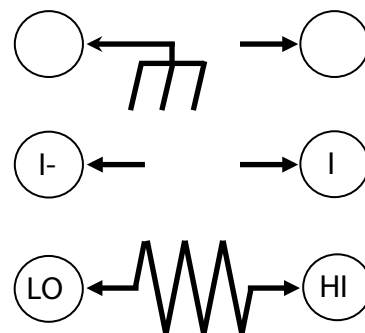

Figure 8 - "W" Case Layout



3.3 Custom Values

Any custom value is available upon request. For custom values, to determine the uncertainty, use the closest nominal value listed in the specification table. Actual uncertainties and measurements will be listed on the ISO/IEC 17025 Calibration Certificate.



4.0 CALIBRATION AND PERFORMANCE VERIFICATION

4.1 Introduction

The following section describes the calibration and performance verification procedures for the 9334A Series of Resistance Standards. It is recommended that Resistance Standards be calibrated at 10 mW of power or less. The listed points in Table 2 are for 10 mW of Power for most values.

4.2 Calibration Overview

This calibration procedure covers the entire range of the 9334A Series of Resistance Standards. The 9334A calibration procedure typically is broken into four distinct resistance ranges with each procedure requiring high order level standards. These ranges are not broken out in the same ranges as the specification table, but instead are listed with respect to the Standards and Procedures required to calibrate the units values

The four resistance ranges of the 9334A Series are:

Low Ohms Resistance: Resistance values from 1 $\mu\Omega$ to 0.1 Ω with currents above 145 mA and less than 100 Amperes. Values in this range are calibrated in controlled air environment at 23 °C. These values require a range extender with a DCC Bridge.

Normal Ohms Resistance: Resistance values in the range 0.1 Ω to 100 k Ω with currents less than 145 mA. Values in this range are calibrated in controlled air environment at 23 °C. These values are in a DCC Bridge current mode of operation.

High Ohms Resistance: Resistance values from 100 k Ω to 1 G Ω with voltages from 10 V to 1000 V. High (and ultra-high) resistance requires voltage vs current as the stimulus. Values in this range are calibrated in controlled air environment at 23 °C. The values are in a DCC Bridge Voltage Mode of operation. Note that the 100 k Ω model can be calibrated with either current or voltage.

Ultra High Ohms resistance: The values range from 1 G Ω to 100 G Ω with calibration voltages from 100 V to 1000 V. Values in this range are calibrated in controlled air environment at 23 °C. An EMI Shielded environment is also recommended. Values in this range are measured by using a Teraohmmeter as a transfer standard and a traceable resistance standard.

4.3 Calibration Interval and Performance

It is recommended that the 9334A series be calibrated or verified on the manufacturer's recommended 12 month interval. As with all resistance standards it is highly recommended that past history be used to determine drift rates. Generally, resistance standards will drift in value more significantly in the first 12 months. After the initial 12 months, drift rates typically become smaller for all models.

It is highly recommended that each 9334A Series be calibrated within a highly controlled temperature environment.

Each 9334A is manufactured to provide some of the best (i.e. lowest) uncertainties when compared to other commercially available resistance standards. After recalibration the user should determine the Resistance Calibration Uncertainties by applying an uncertainty calculation that includes: uncertainties for drift, standards and equipment used; the calibration and laboratory environment; and other uncertainties applicable to that calibration.

Guildline offers ISO/IEC 17025 Accredited DC Resistance Calibration Services from its Smiths Falls, Canada Location. We can provide very good turn-around times with some of the lowest uncertainties available today. 9334A Users may find the use of Guildline Calibration Services an excellent convenience as well as a great alternative to maintaining their own calibration facilities to support these standards. US customers can ship to a US address and Guildline makes all of the arrangements for shipping to and from Canada and for import and export.

4.4 Calibration Temperature Point

The 9334A Series of Resistance Standards are normally calibrated at 23 °C.

The Guildline Instruments 5032 Temperature Air Bath (shown to the right) is recommended to provide the best calibration environment for "air-style" Resistance Standards. This Standard Laboratory Grade Air Bath maintains the temperature environment around the resistance standard to ± 0.03 °C of set point and also provides a highly desirable RF and EMI Shielded environment.

The calibration currents or voltages points for each standard value is listed in Table 2.

**5032 Programmable
Temperature Air Bath**



4.5 Equipment and Standards Required for Calibration

The following Resistance Standards and Test Equipment are required for calibration.

4.5.1 Normal Ohms Calibration Standards (0.1 Ω to 100 k Ω)

Note: Normal Ohms Resistance – 4-Wire resistances in the range 0.1 Ω to 100 k Ω with currents less than 145 mA. Values in this range are calibrated in a controlled temperature air environment at 23 °C.

Use Standards:

Complete 6625A Resistance Measurement System (See Below for Alternative Acceptable Equipment Models)

5030 Series Laboratory Grade Temperature Air Bath

Or (Alternative Standards):

(a) Direct Current Comparator Resistance Bridge (Acceptable Models)

Guildline Instruments 6622A Series DCC Resistance Bridge

Guildline Instruments 6675 or 6675A Series DCC Resistance Bridge

Guildline Instruments Model 9975A Resistance Bridge

(b) Laboratory Grade Primary Resistance Standard (Acceptable Models)

Guildline Instruments 6634A Temperature Stabilized Resistance Standard

Guildline Instruments 6634TS Traveling Standard (Temperature Stabilized)

Guildline Instruments 9334A Standards maintained in a Guildline 5030 Air Bath

Guildline Instruments 9330 Oil Standards maintained in a Guildline Oil or Fluid Bath

(c) Low Thermal Lead Sets or Low Thermal Wire (Acceptable Models)

Guildline 6675A-12 : Precision Lead Set For Resistance Bridge

SCW-30:18AWG : 18 Gauge Low Thermal Wire

(d) Optional (For Automation and Connections)

Guildline 6664B/C 4-Wire, 8 or 16 Channel Low Thermal Scanner (For Automation)

(Note – the Scanner model must be capable of operating at 1000 V)

Guildline Bridgeworks Software

Digital Thermometer (Acceptable Guildline Models 9535, 9540A, 9540B, 9540 or 5150)

4.5.2 Low Ohms Calibration Standards (1 $\mu\Omega$ to 0.1 Ω)

Note: Low Ohms Resistance – resistances in the range 1 $\mu\Omega$ to 0.1 Ω with currents above 145 mA and less than 100 A. Values in this range are calibrated in a controlled temperature air environment at 23 °C.

Use Standards and Equipment Listed In Normal Ohms Calibration and:

6623A Series of Range Extenders from 3A through to 10,000 A
6623-100A Range Extender

Or (Alternative Standards):

Guildline 6623-2A Direct Current Comparator Range Extender with Power Supply (allows current support to 2 Amperes DC and is fully programmable).

4.5.3 High Ohms Calibration Standards (100 k Ω to 1 G Ω)

Note: High Ohms Resistance – resistances in the range 100 k Ω to 1 G Ω with voltages from 10V to 1000V. High (and ultra-high) resistance requires voltage vs current as the stimuli. Values in this range are calibrated in a controlled temperature air environment at 23 °C. It is highly recommended that Standards are enclosed in an EMI shielded environment

Use Standards and Equipment Listed In Normal Ohms Calibration:

Or Alternative Standards:

Note: On Resistance Bridge for Measurement to 100 M Ω , the following Bridges are acceptable alternatives:

6622A-XR
6622A-XPR
6622A-HV
6675 or 6675A Series

For Measurements to 1 G Ω , the following DCC Resistance Bridges are acceptable alternatives:

6622A-HV
6675 or 6675A Series

4.5.4 Ultra High Ohms Calibration Standards (>1 GΩ)

Note: Ultra High Ohms Resistance – resistances in the range 1 GΩ to 100 GΩ with calibration voltages from 100 V to 1000 V. High (and ultra-high) resistance requires voltage vs current as the stimuli. Values in this range are calibrated in air at 23 °C. These resistors are measured using a Teraohmmeter as a transfer standard and a traceable standard resistor.

Use Standards:

Guildline 6535 High Resistance Measurement System or
Guildline Instruments Model 6530 Digital Programmable Teraohmmeter with TeraCal Software with a Characterized Resistance Standard for Short Term Transfer. Models Include:

6636 Temperature Stabilized Resistance Standard or
9336/9337 Series Standard Air Resistors in a Temperature Controlled and EMI Shielded Environment

Guildline 65220 Environmental Monitor (to Record Temp and Humidity)
5030 Series Laboratory Grade Temperature Air Bath which provides both Temperature Control and EMI Shielding

Or (Alternative Standards)

Alternative Measurement Standard with Short Term Transfer Techniques

Guildline Instruments Model 6530, 6520 or 6500A Digital Programmable Teraohmmeter
Resistance Standard for Short Term Transfer:

6636 Temperature Stabilized Resistance Standard
9336/9337 Series Standard Air Resistors in a Temperature Controlled Environment

Guildline 65223 Sample Shielded Enclosure

Optional

Guildline 6564 2-Wire, 8 or 16 Channel Scanner (For Automation of 1MΩ to 100 GΩ)

(Note – the Scanner model must be capable of operating at 1000 V)

Guildline TeraCal Software

Digital Thermometer (Acceptable Guildline Models 9535, 9540A, 9540B, 9540 or 5150)

4.6 Routine Calibration

This routine calibration procedure describes the calibration currents and/or voltages required for the 9334A Resistance Standards. The procedure is intended to be used as a reference for qualified metrology personnel who have a primary level standards laboratory with equipment available to support an instrument of this level of standards accuracy.

Qualified personnel means that the technician or metrologist performing the calibration has the necessary level and understanding on Direct Current Comparator Resistance Measurements and full understanding of the DCC Bridge operation's and will take precautions to avoid introducing errors from sources such as guard errors, thermal emfs, temperature and or EMI errors, connector and lead errors, and other sources of measurement errors. The procedure assumes operators will make adequate allowance for equipment stabilization and measurement settling times.

For the best uncertainties with least influence on the measurements, it is recommended that the procedure use automation technologies such as Bridgeworks Software, IEEE Control and 6664B/C or 6564 Low Thermal Scanners.

Calibration Notes For All Models

Always check availability of equipment and standards prior to starting the calibration. If the required equipment is not available, do not proceed with the calibration.

Ensure all equipment used is within the calibration validity interval.

Before beginning the calibration, inspect the UUT and all leads for damage and cleanliness. If the UUT is not in suitable condition for calibration, please clean or repair before proceeding.

Most of Table 2 recommended calibration points are for 10 mW of Power. For higher values (when Bridge is used in Voltage Mode), points listed may be less than 1 mW due to limitations of the Bridge and/or usage factors. While Table 2 lists recommended calibration points, actual calibration points should include consideration for the intended and/or application of the resistance standards. For example, if a high value resistor is intended to be used from 5 V to 100 V, then the calibration should include enough points that the voltage coefficient of the resistor is minimized or accounted for.

Table 2 - List of Recommended Test Currents or Voltages For Resistance Values

9334A Model	Recommended Current or Voltage	Foot Note	Comments
9334A-1u	50 Adc	1	6623A Series Self Contained Range Extender, or 6623-100A Range Extender with Power Supply
9334A-10u	30 Adc	1	6623A Series Self Contained Range Extender, or 6623-100A Range Extender with Power Supply
9334A-100u	15 Adc	1	6623A Series Self Contained Range Extender, or 6623-100A Range Extender with Power Supply
9334A-0.001	3 Adc	1	6623 or 6623A Series
9334A-0.01	1 Adc	1,2	6623 or 6623A Series
9334A-0.1	150 mAdc	1,2	
9334A-1	100 mAdc	3	
9334A-10	31.6 mAdc	3	
9334A-100	10 mAdc	3	
9334A-1k	3.16 mAdc	3	
9334A-10k	1 mAdc	3	
9334A-100k Optional Cal Point	0.1 mAdc 32 Vdc	4 4,8	Using Voltage Requires 6622A-XR, XPR or HV model. If 6675A or 9975A Available, also use 66001
9334A-1M	100 Vdc	4	
9334A-10M Optional Point	100 Vdc 316 Vdc	4 5	1 mW 10 mW - If 6675A or 9975A Available, also use 66001
9334A-100M Optional Cal Point	100 Vdc 316 Vdc	4,5 5,8	0.1 mW - Can use or add optional Cal Points 1 mW - If 6675A or 9975A Available, also use 66001
9334A-100M Optional Cal Point	990 Vdc	5,8	10 mW - If 6675A or 9975A Available, also use 66001
9334A-1G Optional Cal Point	100 Vdc 990 Vdc	5,6,7 5,8	6622A-HV Model or Teraohmmeter Optional If 6675A or 9975A Available, also use 66001
9334A-10G Optional Cal Point	100 Vdc 990 Vdc	7 5,8	Teraohmmeter Required If 6675A or 9975A Available, also use 66001
9334A-100G	1000 Vdc	7	0.01 mW - Teraohmmeter Required

- 1 – Requires 6623A Series Range Extender
- 2 – Requires either 6623A Series Range Extender or 6623A-2A (With Built in Supply)
- 3 – Can use any of the recommended Bridges
- 4 – For 6622A Series DCC Bridge, must be 6622A-XR or 6622A-XPR Series
- 5 – Voltages above 100 V are only available in the 6622A Series from the 6622A-HV Bridge. If using a 6675 Series or 9975 Series DCC Bridge it is recommended that the 66001 Lead Compensator be used.
- 6 – Alternative Method can use 6530, 6520 or 6500A with Resistance Standard using Short Term Transfer Methods
- 7 – Includes “H” or “W” Series Models
- 8 – Optional Calibration Points can be used in place of the standard calibration point or added to the standard point for calibration.

4.7 Low Ohms Calibration

- (a) Place 9334A into 5030 Series Temperature Stabilized Air Chamber.
- (b) Setup DCC Bridge and Range Extender for appropriate measurement (refer to Standards Manuals used).
- (c) Set chamber temperature to 23 °C and allow to thermally stabilize. Once temperature has stabilized, allow a minimum of 24 hours to soak the resistor.
- (d) While Stabilizing record last calibration date and values as listed in Table 3.
- (e) After equipment and readings have stabilized, record the resistance in the Table 3 reading for temperature of 23 °C in the column for Temp Value.
- (f) When all readings are recorded, go to Data Evaluation and Uncertainty Calculation.

Note: Measurement Tips.

Consider the following when setting up the measurement

Verify that the maximum voltage or current applied in the measurement will not exceed the specs for the UUT or the STD. In no case should you exceed 100 mW of applied power.

Verify the reversal rate is appropriated for the measurement and the uncertainty desired.

Ensure that you know whether the measurement you are reading on the Bridge is either a ratio or actual ohms value.

If using a PC, verify that the number of samples and logging delay are appropriate.

If using a PC set the environmental parameters in BridgeWorks .

Verify guard and ground connections (see 6622A Manual).

If using a Scanner, ensure that the proper channels for Rx and Rs are selected.

4.8 Normal Ohms Calibration

- (a) Place 9334A into 5030 Series Temperature Stabilized Air Chamber.
- (b) Setup DCC for appropriate measurement (refer to Standards Manuals used).
- (c) Set chamber temperature to 23 °C and allow to stabilize a minimum of 12 hours.
- (d) While Stabilizing record last calibration date and values as listed in Table 3.
- (e) While Resistor is stabilizing, set bridge to appropriate settings as referred to in the operators manual for the DCC Bridge that is being used.
- (f) After equipment, and readings have stabilized, record the resistance in Table 3 reading for temperature of 23 °C in the column for Temp Value.
- (g) When all readings are recorded, go to Data Evaluation and Uncertainty Calculation.

Note: Measurement Tips.

Consider the following when setting up the measurement

Verify that the maximum voltage or current applied in the measurement will not exceed the specs for the UUT or the STD. In no case should you exceed 100 mW of applied power.

Verify the reversal rate is appropriated for the measurement and the uncertainty desired.

Ensure that you know whether the measurement you are reading on the Bridge is either a ratio or actual ohms value.

If using a PC, verify that the number of samples and logging delay are appropriate.

If using a PC set the environmental parameters in BridgeWorks .

Verify guard and ground connections (see 6622A Manual).

If using a Scanner, ensure that the proper channels for Rx and Rs are selected.

4.9 High Ohms Calibration

- (a) Place 9334A into 5030 Series Temperature Stabilized Air Chamber.
- (b) Setup DCC Bridge for appropriate measurement (refer to Standards Manuals used).
- (c) Set chamber temperature to 23 °C and allow to stabilize a minimum of 60 minutes.
- (d) While Stabilizing record last calibration date and values as listed in Table 3.
- (e) While Resistor is stabilizing, set Bridge to appropriate settings as referred to in the operators manual for the DCC Bridge that is being used.
- (f) After equipment, and readings have stabilized, record the resistance in Table 3 reading for temperature of 23 °C in the column for Temp Value.
- (g) When all readings are recorded, go to Data Evaluation and Uncertainty Calculation.

Note: Measurement Tips.

Consider the following when setting up the measurement

Verify that the maximum voltage or current applied in the measurement will not exceed the specs for the UUT or the STD. In no case should you exceed 100 mW of applied power.

Verify the reversal rate is appropriated for the measurement and the uncertainty desired.

Ensure that you know whether the measurement you are reading on the Bridge is either a ratio or actual ohms value.

If using a PC, verify that the number of samples and logging delay are appropriate.

If using a PC set the environmental parameters in BridgeWorks .

Verify guard and ground connections (see 6622A Manual).

If using a scanner, ensure that the proper channels for Rx and Rs are selected.

4.10 Ultra-High Ohms Calibration

- (a) Place 9334A into 5030 Series Chamber set to 23 °C.
- (b) Place the 65220 Environmental Monitor next to the 9334A Resistance Standard and connect to the rear input of the 6530 Teraohmmeter.
- (c) Set the 6530 Teraohmmeter to appropriate settings as referred to in the Operators Manual.
- (d) Perform a SHORT TERM TRANSFER for the range that the 9334A Resistor will be using. This transfer is described in the 6530 Teraohmmeter Manual or is automated using the TeraCal Software.
- (e) After equipment and readings have stabilized, record the resistance in Table 4 reading and record the actual temperature as read by the 65220 Environment Monitor or optional Digital Thermometer.
- (f) Repeat this process for additional voltages as required.
- (g) When all readings are recorded, go to Data Evaluation and Uncertainty Calculation.

Note: Measurement Tips.

Consider the following when setting up the measurement

Verify that the maximum voltage applied in the measurement will not exceed the specs for the UUT or the STD. In no case should you exceed 100 mW of applied power or 1000 Vdc.

Shielding the UUT will greatly improve stability of the reading. Using the 65223 or the 5030 Air Bath will provide the necessary shielding.

If using a PC set the environmental parameters in TeraCal.

Verify guard and ground connections (see 6530 Manual).

If using a Scanner, ensure that the proper channels are selected.

Table 3 - Calibration Data Worksheet

9334A Model ▶		Serial Number ▶	
Calibration Dates ▶		LAST CALIBRATION	CURRENT CALIBRATION
Applied Current/Voltage (Table 2) ▶			
Current (I ² R)	Calculated Power ▶		
Voltage (E ² /R)			
		LAST CALIBRATION	CURRENT CALIBRATION
Actual Readings	Temp Value 23 °C ▶		
Drift Specification From Table 1 ▶		_____ ppm/_____	
Calculated ¹	Drift @ 23 °C ▶	_____ ppm	

◀ Note Time Frame(1 Year/6 Months Etc)

Note 1 – To Calculate Drift Specifications using the following formula:

For Drift @ 23 °C (In ppm) Calculate Change (PPM) Using formula:

$$((\text{Current Cal}_{\text{Temp Value } 23\text{ °C}} - \text{Last Cal}_{\text{Temp Value } 23\text{ °C}}) / \text{Last Cal}_{\text{Temp Value } 23\text{ °C}}) * 1\text{E}^6$$

Table 4 - Teraohmmeter Calibration Data Worksheet

9334A Model ▶				Serial Number ▶			
Previous Cal Date ▶				Current Cal Date ▶			
Test Parameters ¹		Voltage	V	Cap	pF	Thresh	V
Reference Resistor Serial Number ▶					Calibration Date		
Charted Reference Value ²					Reference Uncertainty		

65220 Environmental Monitor Readings		Temperature	Humidity	Barometric Pressure
Current Cal	Ref1 Measurement	UUT Measurement	Ref2 Measurement	Corrected Reading ²
Temp Value 23 °C ▶				

		LAST CALIBRATION	CURRENT CALIBRATION
Corrected Readings	Temp Value 23°C ▶		

Drift Specification From Table 1 ▶		_____ ppm/_____	◀ Note Time Frame(1 Year/6 Months Etc)
Calculated ³	Drift @ 23 °C ▶	ppm	

Note 1 – Transfer method:

For the transfer method to remain valid the test setting with respect to **capacitor** and **threshold** **MUST** remain the same for both reference and UUT measurements.

Note 2 – To Calculate Corrected Reading using the following formula:

For Corrected Reading (In Ω) Calculate Value Using formula:

$$\text{UUT Measurement} + [\text{Charted Reference Value} - ((\text{Ref1 Measurement} + \text{Ref2 Measurement})/2)]$$

Note 3 – To Calculate Drift Specifications using the following formula:

For Drift @ 23 °C (In ppm) Calculate Change (PPM) Using formula:

$$((\text{Current Cal}_{\text{Temp Value 23 °C}} - \text{Last Cal}_{\text{Temp Value 23 °C}}) / \text{Last Cal}_{\text{Temp Value 23 °C}}) * 1\text{E}^6$$

5.0 MAINTENANCE

Maintenance of the resistor consists only of routinely inspecting the unit for physical damage and cleanliness. Cleanliness is especially important on the high value resistors (1 MΩ and greater). These should be cleaned with isopropanol and a soft brush or cloth. Special care should be taken to ensure that the terminal connectors are clean and are not cracked or damaged.

5.1 Replaceable Parts

The following tables list the replaceable parts. **Note that once a part has been replaced, the unit may be required to be recalibrated.**

To Contact Guildline Instruments, the following information is provided.

USA and Canada Telephone: (613) 283-3000

USA and Canada Fax: 1-613-283-6082

Outside US and Canada Telephone: +[1] 613 283-3000

Outside US and Canada Fax: [1] +613 283-6082

You can also contact Guildline Instruments Limited via their Email or Websites.

Email is: sales@guildline.com

Website is: www.guildline.com

5.1.1 Common Parts (All Models)

Part Number (GPN#)	Description
813-31082	Case Screws
925-23468	Desiccant
841-04000	Split Lock Washer
19746-01-01	Terminal Washer
30175-01-15	Insulator Top Post
30176-01-15	Insulator Bottom Post
018-02200	Rubber Feet

5.1.2 Terminals 0.001 Ω to 100 G Ω

Part Number (GPN#)	Description
010-24073	Binding Post (Red)
010-24074	Binding Post (Black)
010-21519	Ground Terminal (Gold)

5.1.3 Terminals 100 $\mu\Omega$ and Less

Part Number (GPN#)	Description
30559-01-17	Terminal Cap
30572-01-17	Modified Terminal (Red)
30571-01-17	Modified Ground Terminal (Gold)
30560-01-15	Insulator Left Post
30556-01-15	Insulator Right Post
30557-01-15	Spacer Post
30568-01-15	Spacer
839-06637	Nylon Washer

5.1.4 AH and AW Series Terminals

Part Number (GPN#)	Description
30131-01-17	9334AH Gold Plated (not Flashed) Male Banana Jack
841-01335	Lock Washers #6
19865-01-01	Insulator